

HEAT CONTROLLER, INC.

PACKAGE GAS ELECTRIC UNITS

TGC SERIES HIGH EFFICIENCY 13-SEER

NOMINAL SIZES 3-5 TONS

C VINTAGE



ENGINEERING DESIGN GUIDE

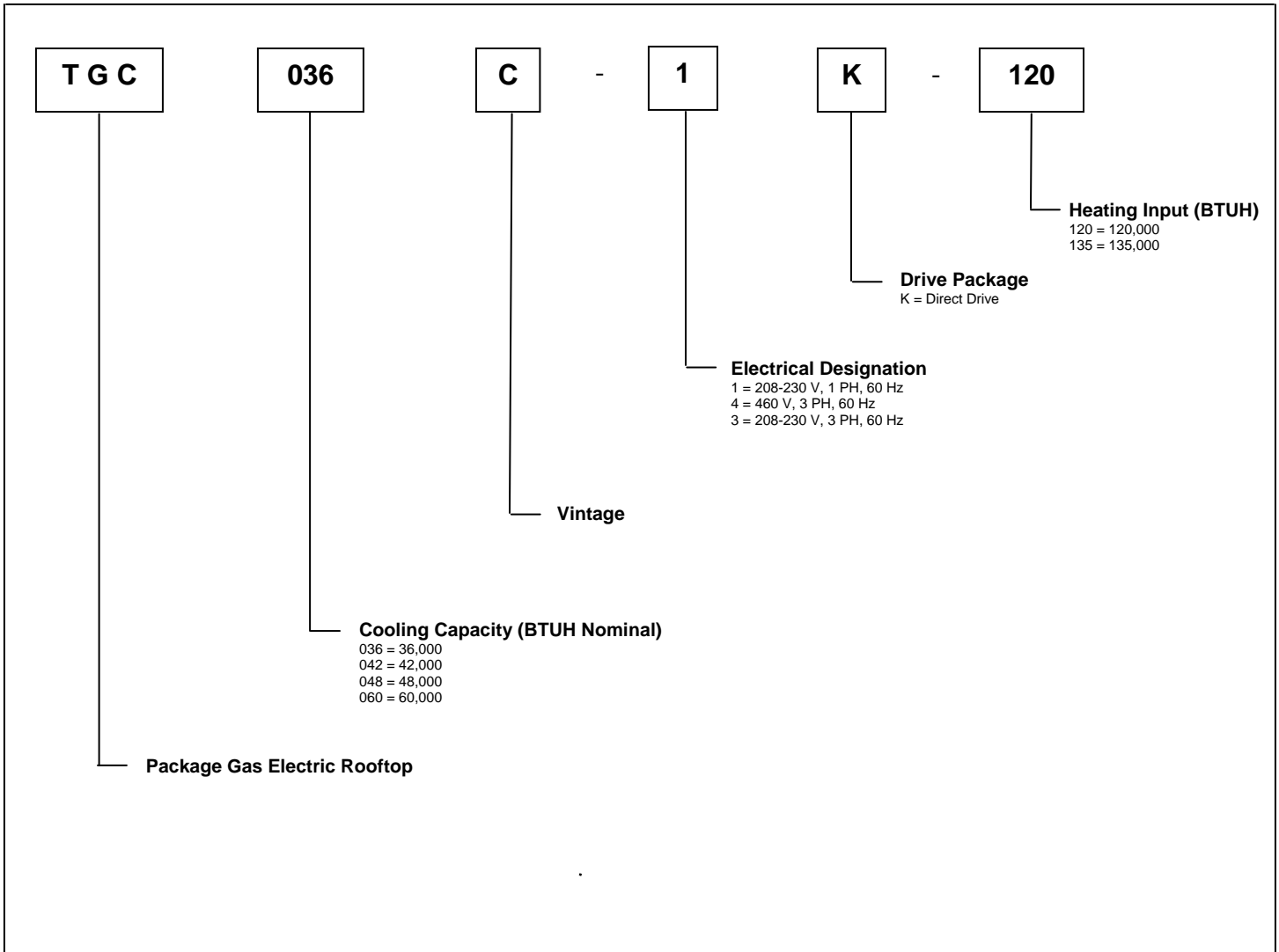

TABLE OF CONTENTS

Model Identification.....	3
Engineering Features	4
Introduction	5
Selection Procedure	6
General Data	7-10
Performance Data.....	11-12
Airflow Performance.....	13-16
Electrical Data	17
Dimensional Data	18-20
Accessories	21-28
Typical Wiring	29-35



MODEL NOMENCLATURE - TGC SERIES



ENGINEERING FEATURES

ENGINEERING FEATURES

TGC Series Package Gas Electric Units

1. All models feature Copeland® Scroll® compressors offering maximum reliability, efficiency, and quiet operation.
2. Aluminized steel heat exchanger with in-shot burners helps eliminate corrosion.
3. Integrated blower/burner control board with built-in diagnostic capability permits on-site trouble shooting.
4. One-piece top over the indoor section with drip lip, drawn painted base pan, and 1" raised flanges for supply/return air connections provides superior water management.
5. Convertible horizontal and vertical airflow design allows maximum field flexibility and minimizes inventory requirements.
6. Standard full perimeter forkable 14 gauge baserail with lifting holes for easier maneuvering and installations.
7. Factory installed one-inch throw away filter with provisions for two-inch filter.
8. Direct drive blowers to accommodate a wide range of design conditions.
9. Easily removable filter, blower, gas heat, and compressor/control access panels permits prompt service.
10. Number and color coded wiring helps facilitate service and maintenance.
11. Common cabinet and components allows for installation flexibility and fewer parts to inventory.
12. Standard freezestat control offers evaporator coil freeze protection.
13. Optional field installed high and low pressure controls.
14. Externally mounted refrigerant gauge ports for easy service diagnostics.
15. Side and base electric power and gas connection entry helps minimize roof penetrations.
16. Quick assembly common roof curbs helps save field labor and maximize size flexibility.
17. Easy to install, plug-in, slip-in, 100% fully modulating economizers.
18. Quality powder paint finish offers long lasting protection against extreme weather conditions and is able to withstand 1000 HR salt spray test.

These quality features are included in the Heat Controller Package Gas Electric Unit

Evaporator Coil/Filter Access

- Return air filters, normally provided, are removed in this photo.

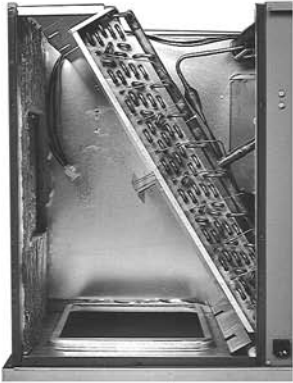

- Corrosion resistant plastic condensate pan



Tubular Heat Exchanger

- Aluminized steel (viewed from supply air side panel.)
- Stainless steel available

Control Box Access



Compressor Access

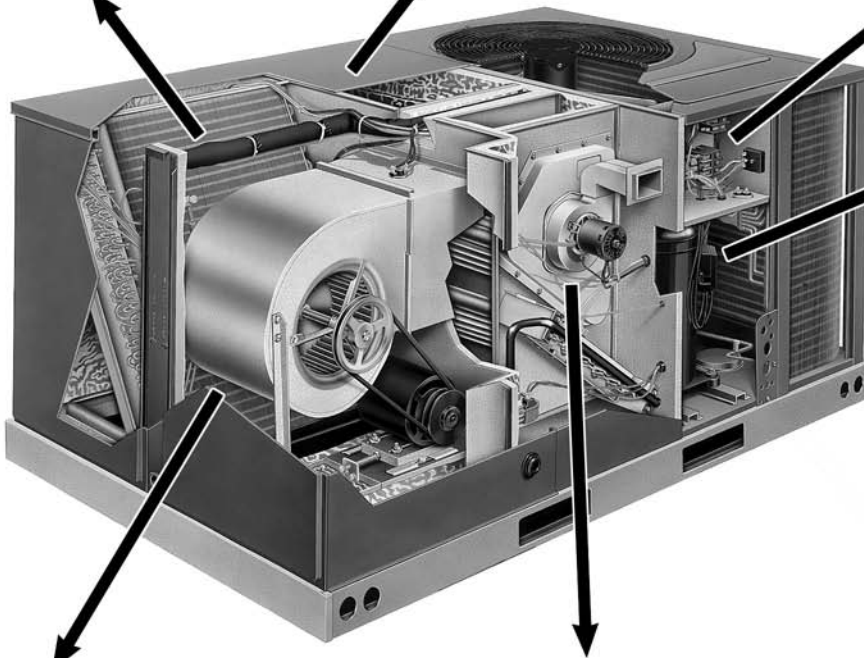

Blower Access

- Belt drive model shown. (On 460 volt 3-phase 5 ton model only.)

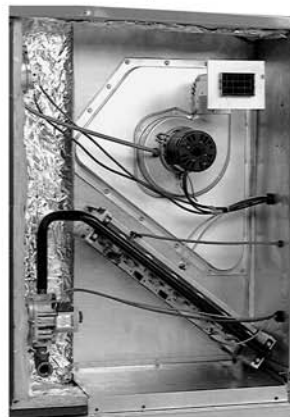

Heating Compartment Access

SELECTION PROCEDURE EXAMPLE

1. Determine cooling and heating requirements at design conditions.

Example:

Total cooling capacity	43,600 BTUH
Sensible cooling capacity	34,000 BTUH
Heating capacity	96,000 BTUH
Condenser entering air	95°F
Evaporator entering air	63°F wbt/76°F dbt
Indoor air flow	1600 CFM
External static pressure.....	0.6 in wg
Required efficiency	13 SEER

2. Select unit to meet cooling requirements.

Since total cooling is within the range of 4 ton unit and requires 13 SEER efficiency level, enter cooling performance from the TGC048C at 95°F outdoor temperature, 63°F wbt entering indoor air, and 1550 CFM:

Total capacity	47,300 BTUH
Power input	3.5 kW

And also, at 76°F db indoor entering air, and using the formula at the bottom of the table:

Sensible capacity	41,708 BTUH
-------------------------	-------------

3. Select heating capacity of the unit.

In the general data tables, note that the heating capacity of the 4 ton model with the 135,000 input heater can deliver 106,500 BTUH, which is suitable for this application.

4. Determine blower speed and power to meet the system requirements.

At the given external static pressure of 0.6 in wg, the belt model must be selected. Enter the belt drive blower performance data at 1580 CFM and 0.6 in wg ESP:

Watts.....635

5. Calculate indoor blower BTUH heat effect.

BTUH = Watts x 3.413 = 2168

6. Calculate net cooling capacities.

Net total cooling = 47,300 – 2168 = 45,132 BTUH

Net sensible cooling = 41,708 – 2168 = 39,540 BTUH



GENERAL DATA

NOMINAL 3 TONS

Model	TGC036C-1K-120	TGC036C-3K-120	TGC036C-4K-120
Cooling Performance¹			
Gross Cooling Capacity Btuh	37400	37400	37400
EER/SEER ²	11.7/13	11.7/13	11.7/13
Nominal CFM/ARI Rated CFM	1200/1200	1200/1200	1200/1200
ARI Net Cooling Capacity Btuh	36000	36000	36000
Net Sensible Capacity Btuh	26400	26400	26400
Net Latent Capacity Btuh	9600	9600	9600
Net System Power kW	3.08	3.08	3.08
Heating Performance (Package Gas/Electric)³			
Heating Input Btuh	120000	120000	120000
Heating Output Btuh	94500	97200	97200
Temperature Rise °F	50-80	50-80	50-80
AFUE (%)	80	80	80
Steady State Efficiency (%)	81	81	81
Qty of Burners	6	6	6
Qty of Stages	1	1	1
Gas Connection Pipe Size, in.	.5	.5	.5
Compressor			
Qty/Type	1/Copeland Scroll		
Outdoor Sound Rating (dB)	78	78	78
Outdoor Coil—Fin Type			
Tube Type	Rifled	Louvered	Rifled
Tube Size in. OD	0.375	0.375	0.375
Face Area sq. ft.	16.91	16.91	16.91
Rows / Fins per inch	1/22	1/22	1/22
Indoor Coil—Fin Type			
Tube Type	Rifled	Corrugated	Rifled
Tube Size in.	0.375	0.375	0.375
Face Area sq. ft.	5.17	5.17	5.17
Rows / Fins per inch	2/17	2/17	2/17
Refrigerant Control	TXV	TXV	TXV
Drain Connection Qty/Size, in.	1/0.75	1/0.75	1/0.75
Outdoor Fan—Type			
Qty Used/Diameter in.	1/24	Propeller	1/24
Drive Type/Speeds	Direct/1	Direct/1	Direct/1
CFM	3680	3680	3680
Qty Motors-HP	1-1/3	1-1/3	1-1/3
Motor RPM	1075	1075	1075
Indoor Fan—Type			
Qty Used/Diameter in.	1/10x10	Forward Curved Centrifugal	1/10x10
Drive Type/Speeds	Direct/3	Direct/3	Direct/3
Motor Qty	1	1	1
Motor HP	1/2	1/2	1/2
Motor RPM	1075	1075	1075
Motor Frame Size	48	48	48
Filter—Type			
Furnished	Yes	Disposable	Yes
(Qty) Size Recommended in.	(2)16x25x1	(2)16x25x1	(2)16x25x1
Refrigerant Charge Oz.			
	93	93	93
Weights			
Net Weight lbs.	543	543	543
Ship Weight lbs.	550	550	550

- Notes:**
1. Cooling performance is rated at 95°F ambient, 80°F/67°F entering dry bulb/wet bulb temperatures. Gross capacity does not include the effect of fan motor heat. ARI capacity is net and includes the effect of fan motor heat. Units are suitable for operation to plus or minus 20% of nominal cfm. Units are certified and rated per ARI Standard 210/240.
 2. EER/SEER are rated ARI condition and accordance with DOE test procedures.
 3. Heating performance limit settings and rating data were established and approved under laboratory test conditions using American National Standard Institute standards. Ratings shown are for elevations up to 2000 feet. For elevations above 2000 feet, rating should be reduced 4% for each 1000 feet above sea level.

NOMINAL 3.5 TONS

Model	TGC042C-1K-120	TGC042C-3K-120	TGC042C-4K-120
Cooling Performance¹			
Gross Cooling Capacity Btuh	43000	43000	43000
EER/SEER ²	11.45/13	11.45/13	11.45/13
Nominal CFM/ARI Rated CFM	1400/1450	1400/1450	1400/1450
ARI Net Cooling Capacity Btuh	41000	41000	41000
Net Sensible Capacity Btuh	30000	30000	30000
Net Latent Capacity Btuh	11000	11000	11000
Net System Power kW	3.59	3.59	3.59
Heating Performance (Package Gas/Electric)³			
Heating Input Btuh	120000	120000	120000
Heating Output Btuh	94500	97200	97200
Temperature Rise °F	50-80	50-80	50-80
AFUE (%)	80	80	80
Steady State Efficiency (%)	81	81	81
Qty of Burners	6	6	6
Qty of Stages	1	1	1
Gas Connection Pipe Size, in.	.5	.5	.5
Compressor			
Qty/Type	1/Copeland Scroll		
Outdoor Sound Rating (dB)	78	78	78
Outdoor Coil—Fin Type			
Tube Type	Rifled	Louvered	Rifled
Tube Size in. OD	0.375	0.375	0.375
Face Area sq. ft.	16.91	16.91	16.91
Rows / Fins per inch	1.53/22	1.53/22	1.53/22
Indoor Coil—Fin Type			
Tube Type	Rifled	Corrugated	Rifled
Tube Size in.	0.375	0.375	0.375
Face Area sq. ft.	5.17	5.17	5.17
Rows / Fins per inch	3/13	3/13	3/13
Refrigerant Control	TXV	TXV	TXV
Drain Connection Qty/Size, in.	1/0.75	1/0.75	1/0.75
Outdoor Fan—Type			
Qty Used/Diameter in.	1/24	Propeller	1/24
Drive Type/Speeds	Direct/1	Direct/1	Direct/1
CFM	3680	3680	3680
Qty Motors-HP	1-1/3	1-1/3	1-1/3
Motor RPM	1075	1075	1075
Indoor Fan—Type			
Qty Used/Diameter in.	1/10x10	Forward Curved Centrifugal	1/10x10
Drive Type/Speeds	Direct/3	Direct/3	Direct/3
Motor Qty	1	1	1
Motor HP	1/2	1/2	1/2
Motor RPM	1725	1725	1725
Motor Frame Size	48	48	48
Filter—Type			
Furnished	Yes	Disposable	Yes
(Qty) Size Recommended in.	(2)16x25x1	(2)16x25x1	(2)16x25x1
Refrigerant Charge Oz.			
	117	117	117
Weights			
Net Weight lbs.	579	579	579
Ship Weight lbs.	586	586	586

- Notes:**
1. Cooling performance is rated at 95°F ambient, 80°F/67°F entering dry bulb/wet bulb temperatures. Gross capacity does not include the effect of fan motor heat. ARI capacity is net and includes the effect of fan motor heat. Units are suitable for operation to plus or minus 20% of nominal cfm. Units are certified and rated per ARI Standard 210/240.
 2. EER/SEER are rated ARI condition and accordance with DOE test procedures.
 3. Heating performance limit settings and rating data were established and approved under laboratory test conditions using American National Standard Institute standards. Ratings shown are for elevations up to 2000 feet. For elevations above 2000 feet, rating should be reduced 4% for each 1000 feet above sea level.

GENERAL DATA

NOMINAL 4 TONS

Model	TGC048C-1K-135	TGC048C-3K-135	TGC048C-4K-135
Cooling Performance¹			
Gross Cooling Capacity Btuh	49000	49000	49000
EER/SEER ²	11.4/13.1	11.4/13.1	11.4/13.1
Nominal CFM/ARI Rated CFM	1600/1550	1600/1550	1600/1550
ARI Net Cooling Capacity Btuh	47000	47000	47000
Net Sensible Capacity Btuh	33600	33600	33600
Net Latent Capacity Btuh	13400	13400	13400
Net System Power kW	4.15	4.15	4.15
Heating Performance (Package Gas/Electric)³			
Heating Input Btuh	135000	135000	135000
Heating Output Btuh	106500	109400	109400
Temperature Rise °F	50-80	50-80	50-80
AFUE (%)	80	80	80
Steady State Efficiency (%)	81	81	81
Qty of Burners	6	6	6
Qty of Stages	1	1	1
Gas Connection Pipe Size, in.	.5	.5	.5
Compressor			
Qty/Type	1/Copeland Scroll		
Outdoor Sound Rating (dB)	78	78	78
Outdoor Coil—Fin Type			
Tube Type	Rifled	Louvered	Rifled
Tube Size in. OD	0.375	0.375	0.375
Face Area sq. ft.	16.56	16.56	16.56
Rows / Fins per inch	2/22	2/22	2/22
Indoor Coil—Fin Type			
Tube Type	Rifled	Corrugated	Rifled
Tube Size in.	0.375	0.375	0.375
Face Area sq. ft.	5.17	5.17	5.17
Rows / Fins per inch	3/15	3/15	3/15
Refrigerant Control	TXV	TXV	TXV
Drain Connection Qty/Size, in.	1/0.75	1/0.75	1/0.75
Outdoor Fan—Type			
Qty Used/Diameter in.	1/24	Propeller	1/24
Drive Type/Speeds	Direct/1	Direct/1	Direct/1
CFM	3680	3680	3680
Qty Motors-HP	1-1/3	1-1/3	1-1/3
Motor RPM	1075	1075	1075
Indoor Fan—Type			
Qty Used/Diameter in.	1/10x10	Forward Curved Centrifugal	1/10x10
Drive Type/Speeds	Direct/3	Direct/3	Direct/3
Motor Qty	1	1	1
Motor HP	1/2	1/2	1/2
Motor RPM	1075	1075	1075
Motor Frame Size	48	48	48
Filter—Type			
Furnished	Yes	Disposable	Yes
(Qty) Size Recommended in.	(2)16x25x1	(2)16x25x1	(2)16x25x1
Refrigerant Charge Oz.			
	167	167	167
Weights			
Net Weight lbs.	585	585	585
Ship Weight lbs.	592	592	592

- Notes:**
- Cooling performance is rated at 95°F ambient, 80°F/67°F entering dry bulb/wet bulb temperatures. Gross capacity does not include the effect of fan motor heat. ARI capacity is net and includes the effect of fan motor heat. Units are suitable for operation to plus or minus 20% of nominal cfm. Units are certified and rated per ARI Standard 210/240.
 - EER/SEER are rated ARI condition and accordance with DOE test procedures.
 - Heating performance limit settings and rating data were established and approved under laboratory test conditions using American National Standard Institute standards. Ratings shown are for elevations up to 2000 feet. For elevations above 2000 feet, rating should be reduced 4% for each 1000 feet above sea level.

GENERAL DATA

NOMINAL 5 TONS

Model	TGC060C-1K-135	TGC060C-3K-135	TGC060C-4K-135
Cooling Performance¹			
Gross Cooling Capacity Btuh	60000	60000	60000
EER/SEER ²	11.6/13	11.6/13	11.6/13
Nominal CFM/ARI Rated CFM	2000/1900	2000/1900	2000/1900
ARI Net Cooling Capacity Btuh	58000	58000	58000
Net Sensible Capacity Btuh	42000	42000	42000
Net Latent Capacity Btuh	16000	16000	16000
Net System Power kW	5	5	5
Heating Performance (Package Gas/Electric)³			
Heating Input Btuh	135000	135000	135000
Heating Output Btuh	106500	109400	109400
Temperature Rise °F	40-70	40-70	40-70
AFUE (%)	80	80	80
Steady State Efficiency (%)	81	81	81
Qty of Burners	6	6	6
Qty of Stages	1	1	1
Gas Connection Pipe Size, in.	.5	.5	.5
Compressor			
Qty/Type		1/Copeland Scroll	
Outdoor Sound Rating (dB)			
	83	78	78
Outdoor Coil—Fin Type			
		Louvered	
Tube Type	Rifled	Rifled	Rifled
Tube Size in. OD	0.375	0.375	0.375
Face Area sq. ft.	16.56	16.56	16.56
Rows / Fins per inch	2/22	2/22	2/22
Indoor Coil—Fin Type			
		Corrugated	
Tube Type	Rifled	Rifled	Rifled
Tube Size in.	0.375	0.375	0.375
Face Area sq. ft.	5.17	5.17	5.17
Rows / Fins per inch	3/15	3/15	3/15
Refrigerant Control	TXV	TXV	TXV
Drain Connection Qty/Size, in.	1/0.75	1/0.75	1/0.75
Outdoor Fan—Type			
		Propeller	
Qty Used/Diameter in.	1/24	1/24	1/24
Drive Type/Speeds	Direct/1	Direct/1	Direct/1
CFM	3930	3930	3930
Qty Motors-HP	1-1/3	1-1/3	1-1/3
Motor RPM	1075	1075	1075
Indoor Fan—Type			
		Forward Curved Centrifugal	
Qty Used/Diameter in.	1/10x10	1/10x10	1/10x10
Drive Type/Speeds	Direct/3	Direct/3	Belt/Variable
Motor Qty	1	1	1
Motor HP	1	1	3/4
Motor RPM	1075	1075	1725
Motor Frame Size	48	48	56
Filter—Type			
		Disposable	
Furnished	Yes	Yes	Yes
(Qty) Size Recommended in.	(2)16x25x1	(2)16x25x1	(2)16x25x1
Refrigerant Charge Oz.			
	160	160	160
Weights			
Net Weight lbs.	597	597	597
Ship Weight lbs.	604	604	604

- Notes:**
1. Cooling performance is rated at 95°F ambient, 80°F/67°F entering dry bulb/wet bulb temperatures. Gross capacity does not include the effect of fan motor heat. ARI capacity is net and includes the effect of fan motor heat. Units are suitable for operation to plus or minus 20% of nominal cfm. Units are certified and rated per ARI Standard 210/240.
 2. EER/SEER are rated ARI condition and accordance with DOE test procedures.
 3. Heating performance limit settings and rating data were established and approved under laboratory test conditions using American National Standard Institute standards. Ratings shown are for elevations up to 2000 feet. For elevations above 2000 feet, rating should be reduced 4% for each 1000 feet above sea level.

GROSS SYSTEM PERFORMANCE DATA—TGC036C

		ENTERING INDOOR AIR @ 80°F [26.7°C] dbE ①									
wbE		71°F [21.7°C]			67°F [19.4°C]			63°F [17.2°C]			
CFM [L/s]		1500 [707.9]	1200 [566.3]	900 [424.8]	1500 [707.9]	1200 [566.3]	900 [424.8]	1500 [707.9]	1200 [566.3]	900 [424.8]	
DR ①		.16	.12	.06	.16	.12	.06	.16	.12	.06	
OUTDOOR DRY BULB TEMPERATURE °F [°C]	75 [23.9]	Total BTUH [kW] Sens BTUH [kW] Power	45.5 [13.33] 27.9 [8.18] 2.2	43.5 [12.75] 24.9 [7.30] 2.2	41.6 [12.19] 22.0 [6.45] 2.1	42.7 [12.51] 33.1 [9.70] 2.2	40.9 [11.99] 29.7 [8.70] 2.1	39.0 [11.43] 26.2 [7.68] 2.1	40.3 [11.81] 37.6 [11.02] 2.2	38.6 [11.31] 33.7 [9.88] 2.1	36.8 [10.79] 29.8 [8.73] 2.1
	80 [26.7]	Total BTUH [kW] Sens BTUH [kW] Power	44.6 [13.07] 27.2 [7.97] 2.3	42.6 [12.48] 24.4 [7.15] 2.3	40.7 [11.93] 21.5 [6.30] 2.2	41.8 [12.25] 32.5 [9.52] 2.3	40.0 [11.72] 29.1 [8.53] 2.3	38.1 [11.17] 25.7 [7.53] 2.2	39.4 [11.55] 37.0 [10.84] 2.3	37.7 [11.05] 33.2 [9.73] 2.3	35.9 [10.52] 29.3 [8.59] 2.2
	85 [29.4]	Total BTUH [kW] Sens BTUH [kW] Power	43.7 [12.81] 26.7 [7.83] 2.5	41.8 [12.25] 23.9 [7.00] 2.4	39.9 [11.69] 21.1 [6.18] 2.4	40.9 [11.99] 32.0 [9.38] 2.4	39.1 [11.46] 28.7 [8.41] 2.4	37.4 [10.96] 25.3 [7.41] 2.3	38.5 [11.28] 36.5 [10.70] 2.4	36.8 [10.79] 32.7 [9.58] 2.4	35.1 [10.29] 28.9 [8.47] 2.3
	90 [32.2]	Total BTUH [kW] Sens BTUH [kW] Power	42.9 [12.57] 26.3 [7.71] 2.6	41.0 [12.02] 23.6 [6.92] 2.5	39.1 [11.46] 20.8 [6.10] 2.5	40.1 [11.75] 31.6 [9.26] 2.6	38.3 [11.22] 28.3 [8.29] 2.5	36.6 [10.73] 25.0 [7.33] 2.5	37.6 [11.02] 36.1 [10.58] 2.6	36.0 [10.55] 32.3 [9.47] 2.5	34.4 [10.08] 28.5 [8.35] 2.5
	95 [35]	Total BTUH [kW] Sens BTUH [kW] Power	42.0 [12.31] 25.9 [7.59] 2.7	40.2 [11.78] 23.2 [6.80] 2.6	38.3 [11.22] 20.5 [6.01] 2.6	39.2 [11.49] 31.1 [9.11] 2.7	37.5 [10.99] 27.9 [8.18] 2.6	35.8 [10.49] 24.6 [7.21] 2.6	36.8 [10.79] 35.7 [10.46] 2.7	35.2 [10.32] 31.9 [9.35] 2.6	33.6 [9.85] 28.2 [8.26] 2.6
	100 [37.8]	Total BTUH [kW] Sens BTUH [kW] Power	41.1 [12.05] 25.4 [7.44] 2.8	39.3 [11.52] 22.8 [6.68] 2.8	37.5 [10.99] 20.1 [5.89] 2.7	38.3 [11.22] 30.7 [9.00] 2.8	36.6 [10.73] 27.5 [8.06] 2.8	34.9 [10.23] 24.3 [7.12] 2.7	35.8 [10.49] 35.2 [10.32] 2.8	34.3 [10.05] 31.5 [9.23] 2.8	32.7 [9.58] 27.8 [8.15] 2.7
	105 [40.6]	Total BTUH [kW] Sens BTUH [kW] Power	40.0 [11.72] 24.9 [7.30] 3.0	38.3 [11.22] 22.3 [6.54] 2.9	36.5 [10.70] 19.7 [5.77] 2.8	37.2 [10.90] 30.1 [8.82] 3.0	35.6 [10.43] 27.0 [7.91] 2.9	34.0 [9.96] 23.8 [6.98] 2.8	34.8 [10.20] 34.7 [10.17] 2.9	33.3 [9.76] 31.0 [9.09] 2.9	31.8 [9.32] 27.4 [8.03] 2.8
	110 [43.3]	Total BTUH [kW] Sens BTUH [kW] Power	38.8 [11.37] 24.2 [7.09] 3.1	37.1 [10.87] 21.7 [6.36] 3.0	35.4 [10.37] 19.1 [5.60] 3.0	36.0 [10.55] 29.4 [8.62] 3.1	34.4 [10.08] 26.4 [7.74] 3.0	32.8 [9.61] 23.3 [6.83] 3.0	33.6 [9.85] 33.6 [9.85] 3.1	32.1 [9.41] 30.4 [8.91] 3.0	30.6 [8.97] 26.9 [7.88] 2.9
	115 [46.1]	Total BTUH [kW] Sens BTUH [kW] Power	37.3 [10.93] 23.3 [6.83] 3.2	35.7 [10.46] 20.9 [6.13] 3.1	34.1 [9.99] 18.4 [5.39] 3.1	34.5 [10.11] 28.6 [8.38] 3.2	33.0 [9.67] 25.6 [7.50] 3.1	31.5 [9.23] 22.6 [6.62] 3.1	32.1 [9.41] 32.1 [9.41] 3.2	30.7 [9.00] 29.6 [8.67] 3.1	29.3 [8.59] 26.2 [7.68] 3.1

GROSS SYSTEM PERFORMANCE DATA—TGC042C

		ENTERING INDOOR AIR @ 80°F [26.7°C] dbE ①									
wbE		71°F [21.7°C]			67°F [19.4°C]			63°F [17.2°C]			
CFM [L/s]		1810 [854.2]	1450 [684.3]	1090 [514.4]	1810 [854.2]	1450 [684.3]	1090 [514.4]	1810 [854.2]	1450 [684.3]	1090 [514.4]	
DR ①		.23	.2	.15	.23	.2	.15	.23	.2	.15	
OUTDOOR DRY BULB TEMPERATURE °F [°C]	75 [23.9]	Total BTUH [kW] Sens BTUH [kW] Power	53.2 [15.59] 32.4 [9.50] 2.5	50.9 [14.92] 29.1 [8.53] 2.5	48.6 [14.24] 25.7 [7.53] 2.4	49.3 [14.45] 38.2 [11.20] 2.5	47.1 [13.80] 34.2 [10.02] 2.5	45.0 [13.19] 30.2 [8.85] 2.4	46.0 [13.48] 43.6 [12.78] 2.5	44.0 [12.90] 39.0 [11.43] 2.5	42.0 [12.31] 34.5 [10.11] 2.4
	80 [26.7]	Total BTUH [kW] Sens BTUH [kW] Power	51.9 [15.21] 31.9 [9.35] 2.7	49.6 [14.54] 28.6 [8.38] 2.6	47.4 [13.89] 25.2 [7.39] 2.6	48.0 [14.07] 37.7 [11.05] 2.7	45.9 [13.45] 33.8 [9.91] 2.6	43.8 [12.84] 29.8 [8.73] 2.6	44.7 [13.10] 43.0 [12.60] 2.7	42.7 [12.51] 38.5 [11.28] 2.6	40.8 [11.96] 34.0 [9.96] 2.6
	85 [29.4]	Total BTUH [kW] Sens BTUH [kW] Power	50.8 [14.89] 31.3 [9.17] 2.8	48.6 [14.24] 28.0 [8.21] 2.8	46.4 [13.60] 24.7 [7.24] 2.7	46.8 [13.72] 37.1 [10.87] 2.8	44.8 [13.13] 33.2 [9.73] 2.7	42.8 [12.54] 29.3 [8.59] 2.7	43.6 [12.78] 42.4 [12.43] 2.8	41.7 [12.22] 38.0 [11.14] 2.7	39.8 [11.66] 33.5 [9.82] 2.7
	90 [32.2]	Total BTUH [kW] Sens BTUH [kW] Power	49.8 [14.59] 30.6 [8.97] 3.0	47.6 [13.95] 27.4 [8.03] 2.9	45.4 [13.31] 24.2 [7.09] 2.8	45.8 [13.42] 36.4 [10.67] 2.9	43.8 [12.84] 32.6 [9.55] 2.9	41.9 [12.28] 28.8 [8.44] 2.8	42.6 [12.48] 41.7 [12.22] 2.9	40.7 [11.93] 37.4 [10.96] 2.9	38.9 [11.40] 33.0 [9.67] 2.8
	95 [35]	Total BTUH [kW] Sens BTUH [kW] Power	48.8 [14.30] 29.9 [8.76] 3.1	46.7 [13.69] 26.7 [7.83] 3.0	44.6 [13.07] 23.6 [6.92] 3.0	44.9 [13.16] 35.7 [10.46] 3.1	42.9 [12.57] 31.9 [9.35] 3.0	41.0 [12.02] 28.2 [8.26] 3.0	41.6 [12.19] 41.0 [12.02] 3.1	39.8 [11.66] 36.7 [10.76] 3.0	38.0 [11.14] 32.4 [9.50] 3.0
	100 [37.8]	Total BTUH [kW] Sens BTUH [kW] Power	47.8 [14.01] 29.2 [8.56] 3.3	45.7 [13.39] 26.1 [7.65] 3.2	43.7 [12.81] 23.1 [6.77] 3.1	43.9 [12.87] 35.0 [10.26] 3.2	42.0 [12.31] 31.3 [9.17] 3.2	40.1 [11.75] 27.7 [8.12] 3.1	40.6 [11.90] 40.3 [11.81] 3.2	38.9 [11.40] 36.1 [10.58] 3.2	37.1 [10.87] 31.9 [9.35] 3.1
	105 [40.6]	Total BTUH [kW] Sens BTUH [kW] Power	46.8 [13.72] 28.6 [8.38] 3.4	44.7 [13.10] 25.6 [7.50] 3.3	42.7 [12.51] 22.6 [6.62] 3.3	42.8 [12.54] 34.4 [10.08] 3.4	41.0 [12.02] 30.8 [9.03] 3.3	39.1 [11.46] 27.2 [7.97] 3.2	39.6 [11.61] 39.6 [11.61] 3.4	37.8 [11.08] 35.6 [10.43] 3.3	36.1 [10.58] 31.4 [9.20] 3.2
	110 [43.3]	Total BTUH [kW] Sens BTUH [kW] Power	45.5 [13.33] 28.1 [8.24] 3.5	43.5 [12.75] 25.1 [7.36] 3.5	41.6 [12.19] 22.2 [6.51] 3.4	41.6 [12.19] 33.9 [9.94] 3.5	39.8 [11.66] 30.3 [8.88] 3.4	38.0 [11.14] 26.8 [7.85] 3.4	38.3 [11.22] 38.3 [11.22] 3.5	36.7 [10.76] 35.1 [10.29] 3.4	35.0 [10.26] 31.0 [9.09] 3.4
	115 [46.1]	Total BTUH [kW] Sens BTUH [kW] Power	44.1 [12.92] 27.7 [8.12] 3.7	42.1 [12.34] 24.8 [7.27] 3.6	40.2 [11.78] 21.9 [6.42] 3.5	40.1 [11.75] 33.5 [9.82] 3.6	38.4 [11.25] 30.0 [8.79] 3.6	36.7 [10.76] 26.5 [7.77] 3.5	36.9 [10.81] 36.9 [10.81] 3.6	35.3 [10.35] 34.8 [10.20] 3.6	33.7 [9.88] 30.7 [9.00] 3.5

DR —Depression ratio
dbE—Entering air dry bulb
wbE—Entering air wet bulb

Total —Total capacity x 1000 BTUH
Sens —Sensible capacity x 1000 BTUH
Power—KW input

NOTES: ① When the entering air dry bulb is other than 80°F [27°C], adjust the sensible capacity from the table by adding $[1.10 \times \text{CFM} \times (1 - \text{DR}) \times (\text{dbE} - 80)]$.

[] Designates Metric Conversions

SYSTEM PERFORMANCE

GROSS SYSTEM PERFORMANCE DATA—TGC048C

		ENTERING INDOOR AIR @ 80°F [26.7°C] dbE ①									
wbE		71°F [21.7°C]			67°F [19.4°C]			63°F [17.2°C]			
CFM [L/s]		1940 [915.5]	1550 [731.5]	1160 [547.4]	1940 [915.5]	1550 [731.5]	1160 [547.4]	1940 [915.5]	1550 [731.5]	1160 [547.4]	
DR ①		.21	.18	.14	.21	.18	.14	.21	.18	.14	
OUTDOOR DRY BULB TEMPERATURE °F [°C]	75 [23.9]	Total BTUH [kW] Sens BTUH [kW] Power	62.9 [18.43] 38.2 [11.20] 2.9	60.2 [17.64] 34.2 [10.02] 2.9	57.5 [16.85] 30.2 [8.85] 2.8	57.6 [16.88] 43.8 [12.84] 2.9	55.1 [16.15] 39.2 [11.49] 2.8	52.6 [15.42] 34.6 [10.14] 2.8	55.7 [16.32] 51.4 [15.06] 2.9	53.3 [15.62] 46.0 [13.48] 2.8	50.9 [14.92] 40.6 [11.90] 2.7
	80 [26.7]	Total BTUH [kW] Sens BTUH [kW] Power	61.0 [17.88] 36.6 [10.73] 3.1	58.4 [17.12] 32.8 [9.61] 3.0	55.7 [16.32] 29.0 [8.50] 3.0	55.7 [16.32] 42.2 [12.37] 3.1	53.3 [15.62] 37.8 [11.08] 3.0	50.9 [14.92] 33.4 [9.79] 2.9	53.8 [15.77] 49.8 [14.59] 3.0	51.5 [15.09] 44.6 [13.07] 3.0	49.1 [14.39] 39.4 [11.55] 2.9
	85 [29.4]	Total BTUH [kW] Sens BTUH [kW] Power	59.3 [17.38] 35.5 [10.40] 3.3	56.8 [16.65] 31.8 [9.32] 3.2	54.2 [15.88] 28.1 [8.24] 3.1	54.1 [15.86] 41.1 [12.05] 3.2	51.7 [15.15] 36.8 [10.79] 3.2	49.4 [14.48] 32.5 [9.52] 3.1	52.2 [15.30] 48.7 [14.27] 3.2	49.9 [14.62] 43.6 [12.78] 3.1	47.6 [13.95] 38.5 [11.28] 3.1
	90 [32.2]	Total BTUH [kW] Sens BTUH [kW] Power	57.9 [16.97] 34.8 [10.20] 3.4	55.4 [16.24] 31.2 [9.14] 3.4	52.9 [15.50] 27.5 [8.06] 3.3	52.6 [15.42] 40.4 [11.84] 3.4	50.3 [14.74] 36.2 [10.61] 3.4	48.0 [14.07] 31.9 [9.35] 3.3	50.7 [14.86] 48.0 [14.07] 3.4	48.5 [14.21] 43.0 [12.60] 3.3	46.3 [13.57] 37.9 [11.11] 3.3
	95 [35]	Total BTUH [kW] Sens BTUH [kW] Power	56.7 [16.62] 34.3 [10.05] 3.6	54.2 [15.88] 30.7 [9.00] 3.6	51.7 [15.15] 27.2 [7.97] 3.5	51.4 [15.06] 39.9 [11.69] 3.6	49.1 [14.39] 35.7 [10.46] 3.5	46.9 [13.75] 31.6 [9.26] 3.5	49.5 [14.51] 47.5 [13.92] 3.6	47.3 [13.86] 42.5 [12.46] 3.5	45.2 [13.25] 37.6 [11.02] 3.4
	100 [37.8]	Total BTUH [kW] Sens BTUH [kW] Power	55.5 [16.27] 34.0 [9.96] 3.8	53.1 [15.56] 30.4 [8.91] 3.7	50.7 [14.86] 26.9 [7.88] 3.6	50.3 [14.74] 39.6 [11.61] 3.8	48.1 [14.10] 35.4 [10.37] 3.7	45.9 [13.45] 31.3 [9.17] 3.6	48.4 [14.18] 47.2 [13.83] 3.7	46.3 [13.57] 42.2 [12.37] 3.7	44.2 [12.95] 37.3 [10.93] 3.6
	105 [40.6]	Total BTUH [kW] Sens BTUH [kW] Power	54.5 [15.97] 33.7 [9.88] 4.0	52.2 [15.30] 30.2 [8.85] 3.9	49.8 [14.59] 26.6 [7.80] 3.8	49.3 [14.45] 39.3 [11.52] 4.0	47.1 [13.80] 35.2 [10.32] 3.9	45.0 [13.19] 31.1 [9.11] 3.8	47.4 [13.89] 46.9 [13.75] 3.9	45.3 [13.28] 42.0 [12.31] 3.8	43.2 [12.66] 37.1 [10.87] 3.8
	110 [43.3]	Total BTUH [kW] Sens BTUH [kW] Power	53.6 [15.71] 33.3 [9.76] 4.2	51.3 [15.03] 29.8 [8.73] 4.1	49.0 [14.36] 26.3 [7.71] 4.0	48.3 [14.16] 38.8 [11.37] 4.1	46.2 [13.54] 34.8 [10.20] 4.0	44.1 [12.92] 30.7 [9.00] 4.0	46.4 [13.60] 46.4 [13.60] 4.1	44.4 [13.01] 41.6 [12.19] 4.0	42.4 [12.43] 36.7 [10.76] 3.9
	115 [46.1]	Total BTUH [kW] Sens BTUH [kW] Power	52.7 [15.44] 32.6 [9.55] 4.3	50.4 [14.77] 29.2 [8.56] 4.2	48.1 [14.10] 25.8 [7.56] 4.2	47.4 [13.89] 38.2 [11.20] 4.3	45.4 [13.31] 34.2 [10.02] 4.2	43.3 [12.69] 30.2 [8.85] 4.1	45.5 [13.33] 45.5 [13.33] 4.3	43.6 [12.78] 41.0 [12.02] 4.2	41.6 [12.19] 36.2 [10.61] 4.1

GROSS SYSTEM PERFORMANCE DATA—TGC060C

		ENTERING INDOOR AIR @ 80°F [26.7°C] dbE ①									
wbE		71°F [21.7°C]			67°F [19.4°C]			63°F [17.2°C]			
CFM [L/s]		2380 [1123.2]	1900 [896.7]	1420 [670.1]	2380 [1123.2]	1900 [896.7]	1420 [670.1]	2380 [1123.2]	1900 [896.7]	1420 [670.1]	
DR ①		.20	.17	.12	.20	.17	.12	.20	.17	.12	
OUTDOOR DRY BULB TEMPERATURE °F [°C]	75 [23.9]	Total BTUH [kW] Sens BTUH [kW] Power	73.0 [21.39] 44.0 [12.90] 3.7	69.8 [20.46] 39.4 [11.55] 3.6	66.6 [19.52] 34.8 [10.20] 3.6	68.1 [19.96] 52.1 [15.27] 3.7	65.2 [19.11] 46.7 [13.69] 3.6	62.2 [18.23] 41.2 [12.07] 3.5	64.2 [18.82] 60.0 [17.58] 3.6	61.4 [17.99] 53.7 [15.74] 3.5	58.6 [17.17] 47.5 [13.92] 3.5
	80 [26.7]	Total BTUH [kW] Sens BTUH [kW] Power	72.0 [21.10] 43.3 [12.69] 3.9	68.9 [20.19] 38.8 [11.37] 3.8	65.8 [19.28] 34.2 [10.02] 3.8	67.2 [19.69] 51.4 [15.06] 3.9	64.2 [18.82] 46.0 [13.48] 3.8	61.3 [17.97] 40.7 [11.93] 3.7	63.2 [18.52] 59.3 [17.38] 3.8	60.5 [17.73] 53.1 [15.56] 3.7	57.7 [16.91] 46.9 [13.75] 3.7
	85 [29.4]	Total BTUH [kW] Sens BTUH [kW] Power	70.7 [20.72] 42.6 [12.48] 4.1	67.7 [19.84] 38.1 [11.17] 4.0	64.6 [18.93] 33.7 [9.88] 4.0	65.9 [19.31] 50.7 [14.86] 4.1	63.0 [18.46] 45.4 [13.31] 4.0	60.2 [17.64] 40.1 [11.75] 3.9	61.9 [18.14] 58.6 [17.17] 4.0	59.3 [17.38] 52.4 [15.36] 3.9	56.6 [16.59] 46.3 [13.57] 3.9
	90 [32.2]	Total BTUH [kW] Sens BTUH [kW] Power	69.3 [20.31] 41.8 [12.25] 4.3	66.2 [19.40] 37.5 [10.99] 4.2	63.2 [18.52] 33.1 [9.70] 4.2	64.4 [18.87] 49.9 [14.62] 4.3	61.6 [18.05] 44.7 [13.10] 4.2	58.8 [17.23] 39.5 [11.58] 4.1	60.5 [17.73] 57.8 [16.94] 4.2	57.8 [16.94] 51.8 [15.18] 4.1	55.2 [16.18] 45.7 [13.39] 4.1
	95 [35]	Total BTUH [kW] Sens BTUH [kW] Power	67.6 [19.81] 41.1 [12.05] 4.5	64.7 [18.96] 36.8 [10.79] 4.5	61.7 [18.08] 32.5 [9.52] 4.4	62.8 [18.40] 49.2 [14.42] 4.5	60.0 [17.58] 44.0 [12.90] 4.4	57.3 [16.79] 38.9 [11.40] 4.3	58.8 [17.23] 57.1 [16.73] 4.4	56.3 [16.50] 51.1 [14.98] 4.4	53.7 [15.74] 45.2 [13.25] 4.3
	100 [37.8]	Total BTUH [kW] Sens BTUH [kW] Power	65.9 [19.31] 40.3 [11.81] 4.8	63.1 [18.49] 36.1 [10.58] 4.7	60.2 [17.64] 31.9 [9.35] 4.6	61.1 [17.91] 48.4 [14.18] 4.7	58.4 [17.12] 43.4 [12.72] 4.6	55.8 [16.35] 38.3 [11.22] 4.5	57.1 [16.73] 56.3 [16.50] 4.7	54.7 [16.03] 50.4 [14.77] 4.6	52.2 [15.30] 44.5 [13.04] 4.5
	105 [40.6]	Total BTUH [kW] Sens BTUH [kW] Power	64.3 [18.84] 39.5 [11.58] 5.0	61.5 [18.02] 35.4 [10.37] 4.9	58.7 [17.20] 31.3 [9.17] 4.8	59.4 [17.41] 47.6 [13.95] 4.9	56.9 [16.68] 42.6 [12.48] 4.8	54.3 [15.91] 37.7 [11.05] 4.7	55.5 [16.27] 55.5 [16.27] 4.9	53.1 [15.56] 49.7 [14.57] 4.8	50.7 [14.86] 43.9 [12.87] 4.7
	110 [43.3]	Total BTUH [kW] Sens BTUH [kW] Power	62.8 [18.40] 38.7 [11.34] 5.2	60.0 [17.58] 34.6 [10.14] 5.1	57.3 [16.79] 30.6 [8.97] 5.0	57.9 [16.97] 46.8 [13.72] 5.1	55.4 [16.24] 41.9 [12.28] 5.0	52.9 [15.50] 37.0 [10.84] 4.9	54.0 [15.83] 54.0 [15.83] 5.1	51.6 [15.12] 49.0 [14.36] 5.0	49.3 [14.45] 43.3 [12.69] 4.9
	115 [46.1]	Total BTUH [kW] Sens BTUH [kW] Power	61.4 [17.99] 37.8 [11.08] 5.4	58.8 [17.23] 33.9 [9.94] 5.3	56.1 [16.44] 29.9 [8.76] 5.2	56.6 [16.59] 45.9 [13.45] 5.3	54.1 [15.86] 41.1 [12.05] 5.2	51.7 [15.15] 36.3 [10.64] 5.1	52.6 [15.42] 52.6 [15.42] 5.3	50.3 [14.74] 48.2 [14.13] 5.2	48.0 [14.07] 42.6 [12.48] 5.1

DR —Depression ratio
dbE—Entering air dry bulb
wbE—Entering air wet bulb

Total —Total capacity x 1000 BTUH
Sens —Sensible capacity x 1000 BTUH
Power—KW input

NOTES: ① When the entering air dry bulb is other than 80°F [27°C], adjust the sensible capacity from the table by adding $[1.10 \times \text{CFM} \times (1 - \text{DR}) \times (\text{dbE} - 80)]$.

[] Designates Metric Conversions

DIRECT-DRIVE 208 VOLT AIRFLOW PERFORMANCE

Unit Model	Motor Speed From Factory		Heating Input BTU/hr [kW]	Manufacturer Recommended Air-Flow Range (Min/Max) CFM	Blower Size/ Motor HP [w] # of Speeds	Motor Speed	CFM [L/s] Air Delivery/RPM/Watts—208 Volts								
	Cool	Heat					External Static Pressure—Inches W.C. [kPa]								
							0.1 [0.02]	0.2 [0.05]	0.3 [0.07]	0.4 [0.10]	0.5 [0.12]	0.6 [0.15]	0.7 [0.17]	0.8 [0.20]	
TGC036	Low	Med	80,000 [23.45]	1050/1350	10x10 1/2 HP [373] 3 Speed Motor	Low	CFM	1210 [571]	1193 [563]	1175 [555]	1155 [545]	1125 [531]	1075 [507]	1015 [479]	925 [437]
			Watts				450	400	395	385	380	375	370	360	
			CFM				1515 [715]	1500 [708]	1475 [696]	1450 [684]	1405 [663]	1350 [637]	1275 [602]	1180 [557]	
	High	Med	120,000 [35.17]				Watts	525	510	505	490	475	460	445	
			CFM				1680 [793]	1650 [779]	1625 [767]	1580 [746]	1530 [722]	1460 [689]	1390 [656]	1280 [604]	
			Watts				650	640	630	610	580	560	545	515	
TGC042	Med	Med	80,000 [23.45]	1225/1575	10x10 1/2 HP [373] 3 Speed Motor	Low	CFM	1210 [571]	1193 [563]	1175 [555]	1155 [545]	1125 [531]	1075 [507]	1015 [479]	925 [437]
			Watts				450	400	395	385	380	375	370	360	
			CFM				1515 [715]	1500 [708]	1475 [696]	1450 [684]	1405 [663]	1350 [637]	1275 [602]	1180 [557]	
	High	Med	120,000 [35.17]				Watts	525	510	505	490	475	460	445	
			CFM				1680 [793]	1650 [779]	1625 [767]	1580 [746]	1530 [722]	1460 [689]	1390 [656]	1280 [604]	
			Watts				650	640	630	610	580	560	545	515	
TGC048	Med	Med	80,000 [23.45]	1400/1800	10x10 1/2 HP [373] 3 Speed Motor	Low	CFM	1210 [571]	1193 [563]	1175 [555]	1155 [545]	1125 [531]	1075 [507]	1015 [479]	925 [437]
			Watts				450	400	395	385	380	375	370	360	
			CFM				1515 [715]	1500 [708]	1475 [696]	1450 [684]	1405 [663]	1350 [637]	1275 [602]	1180 [557]	
	High	Med	100,000 [29.31]				Watts	525	510	505	490	475	460	445	
			CFM				1680 [793]	1650 [779]	1625 [767]	1580 [746]	1530 [722]	1460 [689]	1390 [656]	1280 [604]	
			Watts				650	640	630	610	580	560	545	515	
TGC060	Med	Med	100,000 [29.31]	1750/2250	10x10 1 HP [745] 3 Speed Motor	Low	CFM	1575 [743]	1536 [725]	1496 [706]	1457 [688]	1417 [669]	1377 [650]	1338 [631]	1298 [613]
			Watts				297	314	330	347	364	381	397	414	
			CFM				1985 [937]	1954 [922]	1919 [906]	1876 [885]	1824 [861]	1759 [830]	1679 [792]	1581 [746]	
	High	Med	135,000 [39.56]				Watts	535	553	574	593	606	609	599	572
			CFM				2431 [1147]	2372 [1119]	2306 [1088]	2228 [1051]	2138 [1009]	2032 [959]	1907 [900]	1762 [832]	
			Watts				970	981	964	926	872	806	736	665	

[] Designates Metric Conversions

AIRFLOW PERFORMANCE—DIRECT DRIVE

DIRECT-DRIVE 230 VOLT AIRFLOW PERFORMANCE

Unit Model	Motor Speed From Factory		Heating Input BTU/hr [kW]	Manufacturer Recommended Air-Flow Range (Min/Max) CFM	Blower Size/ Motor HP [w] # of Speeds	Motor Speed	CFM [L/s] Air Delivery/RPM/Watts—230 Volts									
	Cool	Heat					External Static Pressure—Inches W.C. [kPa]									
							0.1 [.02]	0.2 [.05]	0.3 [.07]	0.4 [.10]	0.5 [.12]	0.6 [.15]	0.7 [.17]	0.8 [.20]		
TGC036		Low	80,000 [23.45]	1050/1350	10x10 1/2 HP [373] 3 Speed Motor	Low	CFM	1400 [661]	1375 [649]	1360 [642]	1335 [630]	1305 [616]	1255 [592]	1210 [571]	1100 [519]	
		Med	120,000 [35.17]				Watts	470	460	455	450	440	435	425	410	
	Low						CFM	1685 [795]	1620 [765]	1580 [746]	1550 [732]	1500 [708]	1430 [675]	1350 [637]	1230 [580]	
TGC042		Med	120,000 [35.17]	1225/1575	10x10 1/2 HP [373] 3 Speed Motor	Med	CFM	1685 [795]	1620 [765]	1580 [746]	1550 [732]	1500 [708]	1430 [675]	1350 [637]	1230 [580]	
							Watts	635	600	580	570	550	535	505	475	
	Med						CFM	1870 [883]	1830 [864]	1790 [845]	1730 [816]	1660 [783]	1580 [746]	1500 [708]	1375 [649]	
TGC048		Low	80,000 [23.45]	1400/1800	10x10 1/2 HP [373] 3 Speed Motor	Low	CFM	1400 [661]	1375 [649]	1360 [642]	1335 [630]	1305 [616]	1255 [592]	1210 [571]	1100 [519]	
		Med	100,000 [29.31]				Watts	470	460	455	450	440	435	425	410	
	Med						CFM	1685 [795]	1620 [765]	1580 [746]	1550 [732]	1500 [708]	1430 [675]	1350 [637]	1230 [580]	
TGC060		High	135,000 [39.56]	1750/2250	10x10 1 HP [745] 3 Speed Motor	High	CFM	1870 [883]	1830 [864]	1790 [845]	1730 [816]	1660 [783]	1580 [746]	1500 [708]	1375 [649]	
		Low	100,000 [29.31]				Watts	780	760	740	700	660	635	600	555	
	Med						CFM	1575 [743]	1536 [725]	1496 [706]	1457 [688]	1417 [669]	1377 [650]	1338 [631]	1298 [613]	
TGC060		High	135,000 [39.56]	1750/2250	10x10 1 HP [745] 3 Speed Motor	High	CFM	1985 [937]	1954 [922]	1919 [906]	1876 [885]	1824 [861]	1759 [830]	1679 [792]	1581 [746]	
							Watts	535	553	574	593	606	609	599	572	
	High						CFM	2431 [1147]	2372 [1119]	2306 [1088]	2228 [1051]	2138 [1009]	2032 [959]	1907 [900]	1762 [832]	
							Watts	970	981	964	926	872	806	736	665	

Heat Controller, Inc.

[] Designates Metric Conversions

DIRECT-DRIVE 460 VOLT AIRFLOW PERFORMANCE

Unit Model	Motor Speed From Factory		Heating Input BTU/hr [KW]	Manufacturer Recommended Air-Flow Range (Min/Max) CFM	Blower Size/ Motor HP [W] # of Speeds	Motor Speed	CFM [L/s] Air Delivery/RPM/Watts—460 Volts								
	Cool	Heat					External Static Pressure—Inches W.C. [kPa]								
							0.1 [.02]	0.2 [.05]	0.3 [.07]	0.4 [.10]	0.5 [.12]	0.6 [.15]	0.7 [.17]	0.8 [.20]	
TGC036	Low	Low	80,000 [23.45]	1050/1350	10x10 1/2 HP [373] 3 Speed Motor	Low	CFM	1400 [661]	1375 [649]	1360 [642]	1335 [630]	1305 [616]	1255 [592]	1210 [571]	1100 [519]
			Watts				470	460	455	450	440	435	425	410	
			CFM				1685 [795]	1620 [765]	1580 [746]	1550 [732]	1500 [708]	1430 [675]	1350 [637]	1230 [580]	
	Watts	635	600				580	570	550	535	505	475			
	High	High	CFM				1870 [883]	1830 [864]	1790 [845]	1730 [816]	1660 [783]	1580 [746]	1500 [708]	1375 [649]	
			Watts				780	760	740	700	660	635	600	555	
CFM			1400 [661]	1375 [649]	1360 [642]	1335 [630]	1305 [616]	1255 [592]	1210 [571]	1100 [519]					
TGC042	Med	Med	80,000 [23.45]	1225/1575	10x10 1/2 HP [373] 3 Speed Motor	Med	CFM	1685 [795]	1620 [765]	1580 [746]	1550 [732]	1500 [708]	1430 [675]	1350 [637]	1230 [580]
			Watts				635	600	580	570	550	535	505	475	
			CFM				1870 [883]	1830 [864]	1790 [845]	1730 [816]	1660 [783]	1580 [746]	1500 [708]	1375 [649]	
	Watts	780	760				740	700	660	635	600	555			
	High	High	CFM				1400 [661]	1375 [649]	1360 [642]	1335 [630]	1305 [616]	1255 [592]	1210 [571]	1100 [519]	
			Watts				470	460	455	450	440	435	425	410	
CFM			1685 [795]	1620 [765]	1580 [746]	1550 [732]	1500 [708]	1430 [675]	1350 [637]	1230 [580]					
TGC048	High	High	100,000 [29.31]	1400/1800	10x10 1/2 HP [373] 3 Speed Motor	High	CFM	1870 [883]	1830 [864]	1790 [845]	1730 [816]	1660 [783]	1580 [746]	1500 [708]	1375 [649]
			Watts				780	760	740	700	660	635	600	555	
			CFM				1400 [661]	1375 [649]	1360 [642]	1335 [630]	1305 [616]	1255 [592]	1210 [571]	1100 [519]	
	Watts	470	460				455	450	440	435	425	410			
	High	High	CFM				1685 [795]	1620 [765]	1580 [746]	1550 [732]	1500 [708]	1430 [675]	1350 [637]	1230 [580]	
			Watts				635	600	580	570	550	535	505	475	
CFM			1870 [883]	1830 [864]	1790 [845]	1730 [816]	1660 [783]	1580 [746]	1500 [708]	1375 [649]					
Watts	780	760	740	700	660	635	600	555							

[] Designates Metric Conversions

AIRFLOW PERFORMANCE—BELT DRIVE

AIRFLOW PERFORMANCE—5 TON BELT DRIVE

Air Flow CFM [L/s]	Capacity 5 Ton [17.6 kW]—13 SEER		External Static Pressure—Inches of Water [kPa]																													
	Voltage 460—3 Phase		0.1 [.02]		0.2 [.05]		0.3 [.07]		0.4 [.10]		0.5 [.12]		0.6 [.15]		0.7 [.17]		0.8 [.20]		0.9 [.22]		1.0 [.25]		1.1 [.27]		1.2 [.30]		1.3 [.32]		1.4 [.35]		1.5 [.37]	
	RPM	W	RPM	W	RPM	W	RPM	W	RPM	W	RPM	W	RPM	W	RPM	W	RPM	W	RPM	W	RPM	W	RPM	W	RPM	W	RPM	W	RPM	W		
1400 [661]	—	—	—	—	780	370	780	415	815	425	875	460	930	480	1030	540	1065	570	1105	595	1150	615	1195	645	1235	660	1300	705	1340	745		
1500 [708]	—	—	—	—	795	405	840	415	895	440	945	500	995	540	1045	595	1080	615	1135	650	1165	675	1215	700	1255	735	1320	775	1355	805		
1600 [755]	—	—	—	—	780	390	805	425	870	470	915	510	965	600	1060	640	1105	680	1145	705	1180	730	1225	750	1275	790	1340	840	1365	880		
1700 [802]	—	—	—	—	795	450	840	490	895	530	940	570	990	605	1035	640	1075	680	1120	725	1160	755	1200	790	1245	815	1300	855	1355	905		
1800 [850]	780	455	815	470	870	540	915	560	965	615	1010	660	1055	710	1100	760	1140	785	1175	810	1225	850	1260	880	1320	930	1365	985	1390	1020		
1900 [897]	800	485	850	530	895	590	945	640	995	675	1035	720	1070	775	1120	810	1160	850	1200	890	1245	915	1290	960	1335	1000	1375	1050	1405	1100		
2000 [944]	830	550	880	605	930	655	970	700	1015	730	1055	790	1105	830	1145	875	1180	910	1225	950	1260	980	1320	1035	1075	1385	1120	—	—	—		
2100 [991]	860	615	915	665	955	705	1005	760	1040	820	1090	870	1130	910	1170	950	1210	995	1250	1020	1290	1060	1335	1100	1370	1150	1400	1200	—	—	—	
2200 [1038]	895	680	945	735	995	780	1030	830	1060	880	1120	940	1155	980	1195	1020	1240	1055	1275	1100	1320	1140	1360	1180	1385	1225	—	—	—	—	—	
2300 [1085]	940	755	975	795	1015	830	1065	910	1100	965	1150	105	1180	1050	1225	1095	1265	1125	1310	1175	1350	1230	1375	1260	1405	1320	—	—	—	—	—	
2400 [1133]	970	825	1015	880	1040	925	1095	1005	1145	1055	1175	1085	1225	1140	1260	1175	1300	1210	1340	1255	1370	1315	1400	1375	—	—	—	—	—	—	—	
2500 [1179]	1015	910	1040	935	1095	1040	1145	1100	1170	1140	1200	1175	1260	1215	1305	1270	1360	1350	1400	1395	—	—	—	—	—	—	—	—	—	—	—	

NOTE: L-Drive left of bold line, Consult factory for operation to the right of bold line.

Drive Package	L
Motor H.P. [W]	3/4 [559]
Blower Sheave	6.4" Pitch Diameter
Motor Sheave	2.8"-3.8" Pitch Diameter—Adj.
Turns Open	0 1 2 3 4 5 6
RPM	1095 1040 995 940 890 835 780

NOTE: Factory sheave settings are shown in bold print.

[] Designates Metric Conversions

ELECTRICAL DATA

MODEL	TGC036C-1K-120	TGC036C-3K-120	TGC036C-4K-120	TGC042C-1K-120	TGC042C-3K-120	TGC042C-4K-120
Unit Information						
Unit Operating Voltage Range	187-253	187-253	414-506	187-253	187-253	414-506
Minimum Circuit Ampacity	24/24	18/18	11	30/30	21/21	11
Max. Overcurrent Protection Device Size	35/35	25/25	15	45/45	30/30	15
Compressor						
Quantity	1	1	1	1	1	1
Volts	208/230	208/230	460	208/230	208/230	460
Phase	1	3	3	1	3	3
HP	3	3	3	3 1/2	3 1/2	3 1/2
RPM	3450	3450	3450	3450	3450	3450
Amps (RLA)	14.4/14.4	9.6/9.6	5.8	19.2/19.2	12.2/12.2	5.8
Amps (LRA)	77/77	88/88	38	104/104	88/88	44
Condenser Fan Motor						
Quantity	1	1	1	1	1	1
Volts	208/230	208/230	460	208/230	208/230	460
Phase	1	1	1	1	1	1
HP	1/3	1/3	1/3	1/3	1/3	1/3
Amps (FLA)	1.5	1.5	1.0	1.5	1.5	1.0
Amps (LRA)	3.0	3.0	1.9	3.0	3.0	1.9
Evaporator Fan Motor						
Quantity	1	1	1	1	1	1
Volts	208/230	208/230	460	208/230	208/230	460
Phase	1	1	1	1	1	1
HP	1/2	1/2	1/2	1/2	1/2	1/2
Amps (FLA)	4.0	4.0	2.0	4.0	4.0	2.0
Amps (LRA)	6.7	6.7	3.6	6.7	6.7	3.6

ELECTRICAL DATA

MODEL	TGC048C-1K-135	TGC0C-3K-135	TGC048C-4K-135	TGC060C-1K-135	TGC060C-3K-135	TGC060C-4K-135
Unit Information						
Unit Operating Voltage Range	187-253	187-253	414-506	187-253	187-253	414-506
Minimum Circuit Ampacity	31/31	21/21	11	42/42	30/30	12
Max. Overcurrent Protection Device Size	50/50	30/30	15	60/60	40/40	15
Compressor						
Quantity	1	1	1	1	1	1
Volts	208/230	208/230	460	208/230	208/230	460
Phase	1	3	3	1	3	3
HP	4	4	4	5	5	5
RPM	3450	3450	3450	3450	3450	3450
Amps (RLA)	20.2/20.2	12.2/12.2	6.1	25.3/25.3	15.4/15.4	7.1
Amps (LRA)	137/137	80.8/80.8	41	141/141	110/110	52
Condenser Fan Motor						
Quantity	1	1	1	1	1	1
Volts	208/230	208/230	460	208/230	208/230	460
Phase	1	1	1	1	1	1
HP	1/3	1/3	1/3	1/3	1/3	1/3
Amps (FLA)	1.5	1.5	1.0	2.2	2.2	1.0
Amps (LRA)	3.0	3.0	1.9	4.9	4.9	1.9
Evaporator Fan Motor						
Quantity	1	1	1	1	1	1
Volts	208/230	208/230	460	208/230	208/230	460
Phase	1	1	1	1	1	3
HP	1/2	1/2	1/2	1	1	3/4
Amps (FLA)	4.0	4.0	2.0	7.6	7.6	1.6
Amps (LRA)	6.7	6.7	3.6	0	0	8.4

UNIT DIMENSIONS

UNIT DIMENSIONS PACKAGE GAS ELECTRIC UNITS

TGR036C-TGR060C MODELS

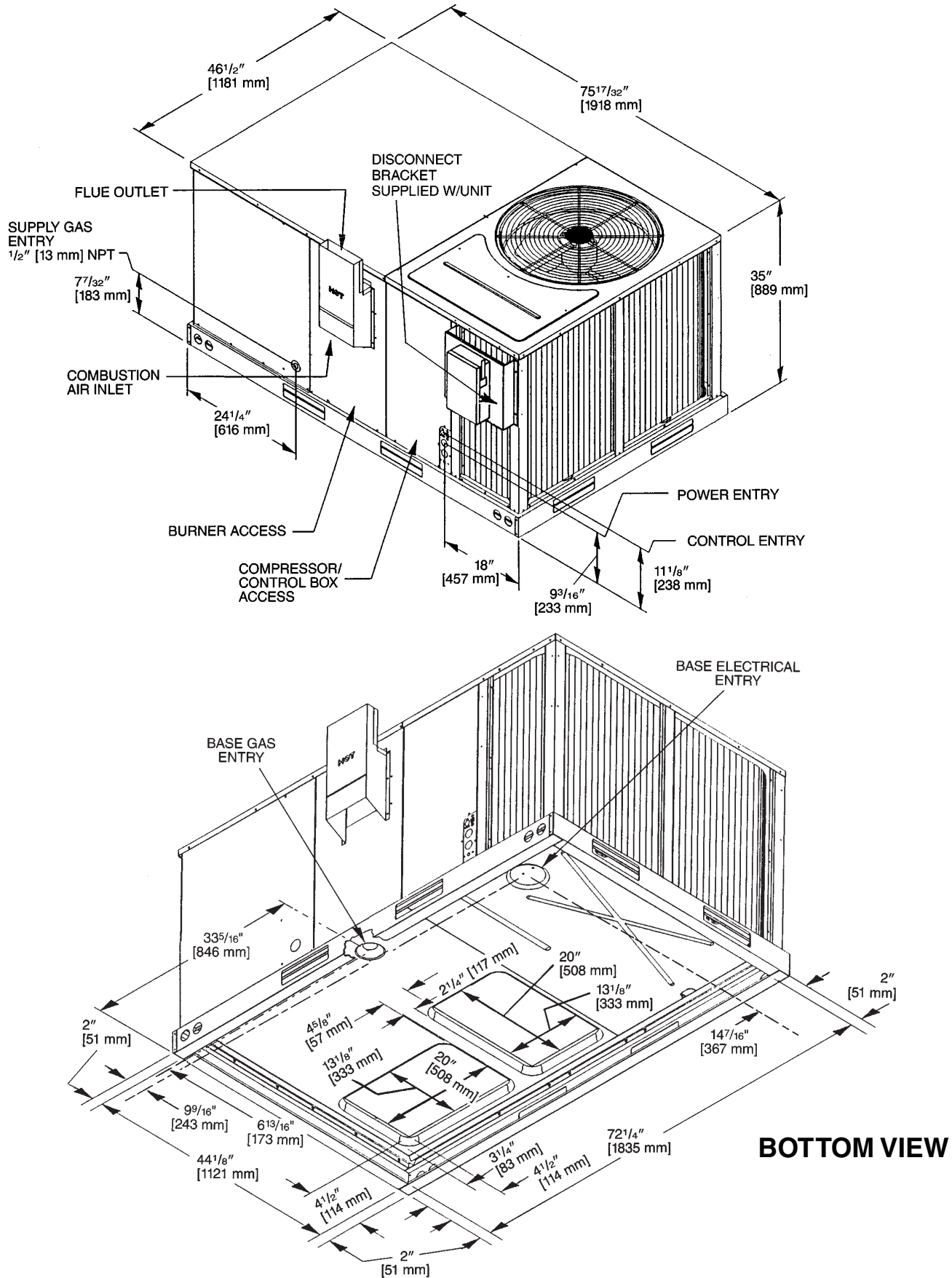

UNIT DIMENSIONS PACKAGE GAS ELECTRIC UNITS

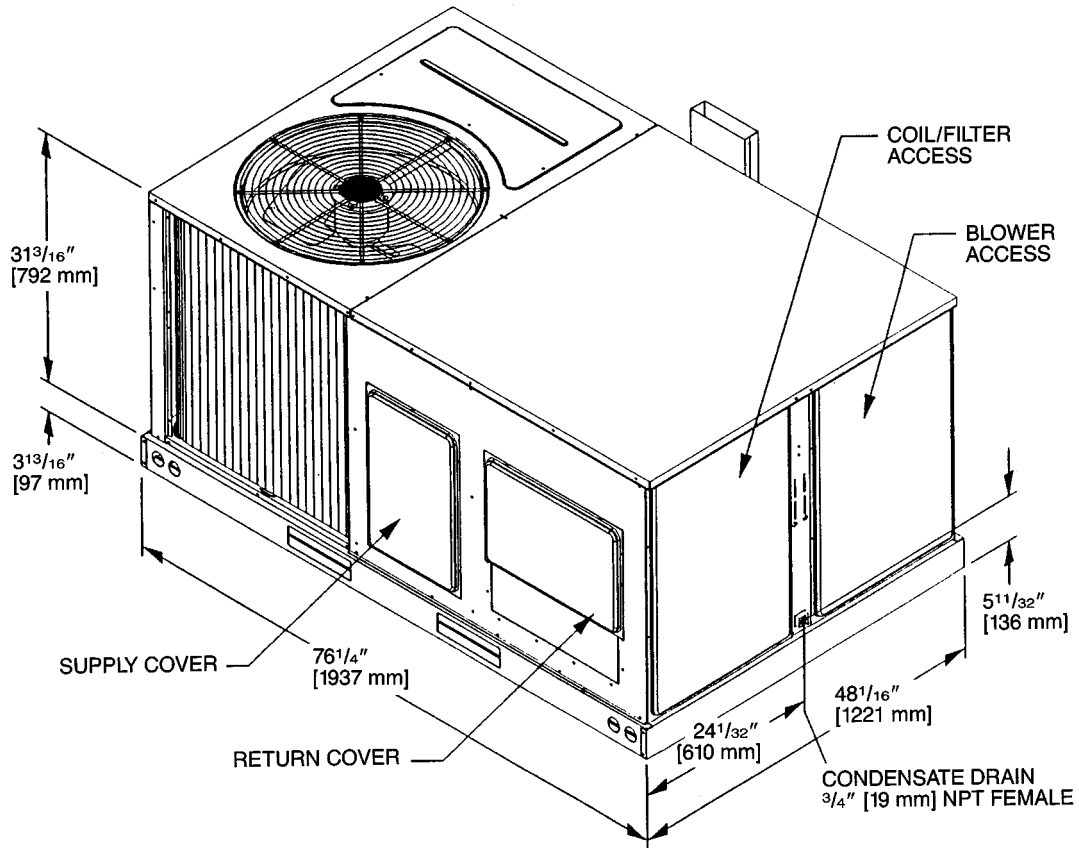

SUPPLY AND RETURN DIMENSIONS

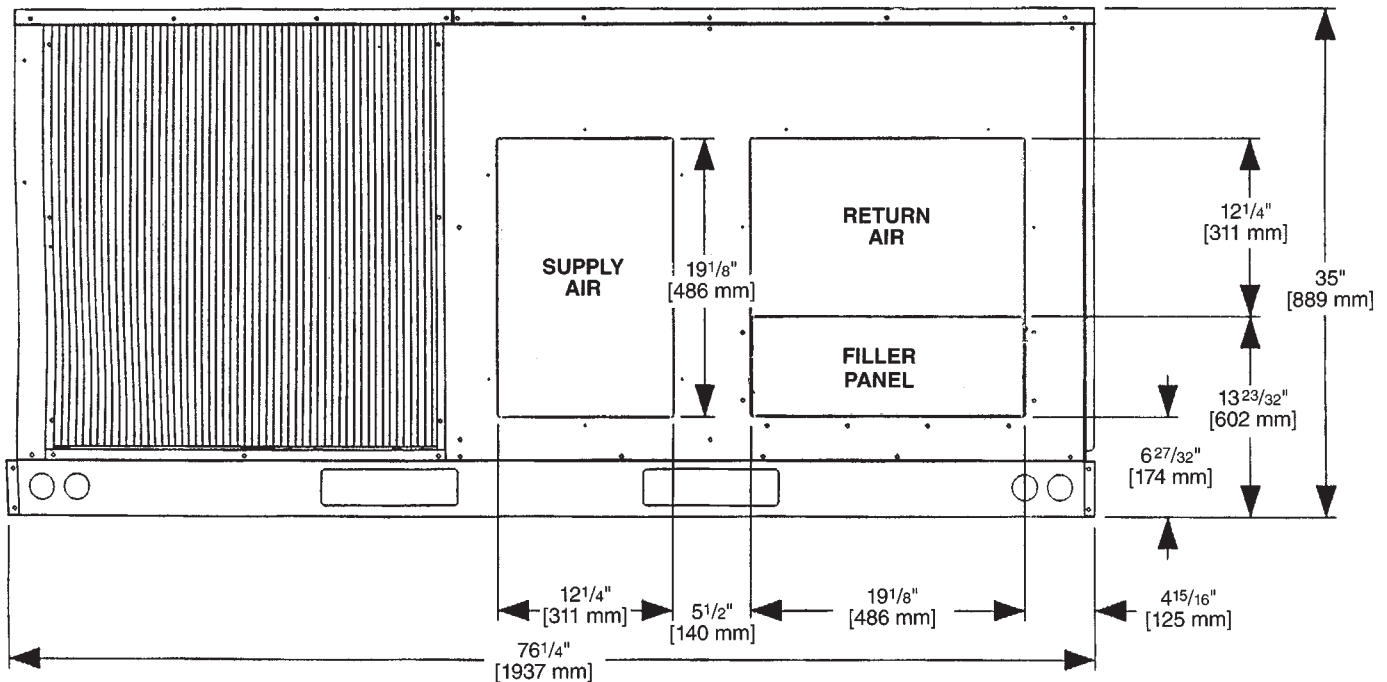

UNIT²⁰ DIMENSIONS

WEIGHTS

Accessory	3-5 Ton [10.6-17.6 kW]	
	Shipping	Operating
	lbs [kg]	lbs [kg]
Economizer with Single Enthalpy	70 [32]	60 [27]
Power Exhaust	19 [9]	16 [7]
Fresh Air Damper (Manual)	11 [5]	9 [4]
Fresh Air Damper (Motorized)	13 [6]	11 [5]
Roof Curb 14"	92 [42]	88 [40]
Roof Curb 24"	108 [49]	104 [47]
Concentric Diffuser 18" Flush	37 [17]	26 [12]
Concentric Diffuser 20" Flush	54 [24]	42 [19]
Side Discharge Concentric Diffuser RXRN-FA60	35 [16]	20 [9]
Side Discharge Concentric Diffuser RXRN-FA65	55 [25]	40 [18]

CENTER OF GRAVITY (C.G.)

Capacity Tons [kW]	A in. [mm]	B in. [mm]
3-5 [10.6-17.6]	38 ¹ / ₄ [972]	25 ³ / ₄ [654]

Capacity Tons [kW]	Corner Weights by Percentage			
	A	B	C	D
3-5 [10.6-17.6]	22%	27%	23%	28%

CLEARANCES

(3 to 5 Ton [10.6 to 17.6 kW] Models)

The following minimum clearances are recommended for proper unit performance and serviceability.

Recommended Clearance in. [mm]	Location
48 [1219]	A - Front
18 [457]	B - Condenser Coil
12 [305]	C - Duct Side
36 [914]	D - Evaporator End
60 [1524]	E - Above

*Without Economizer. 57" [1448 mm] With Economizer

NOTE: Supply duct may be installed with "0" inch clearance to combustible materials, provided 1" minimum Fiberglass insulation is applied either inside or on the outside of the duct.

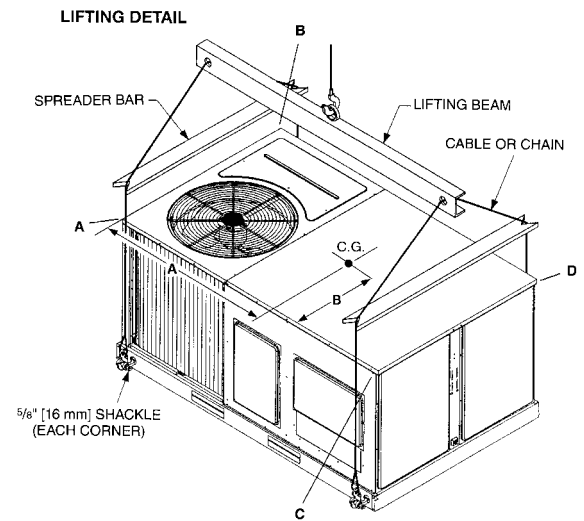
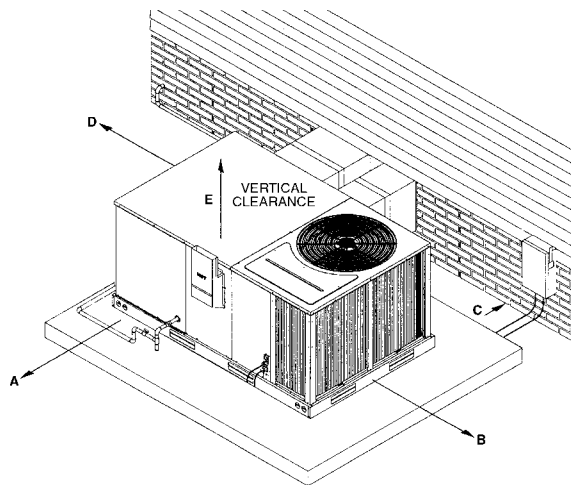

ACCESSORY EQUIPMENT-FIELD INSTALLED

Accessory Description		Accessory Model No. 3 to 5 Ton	
Roofcurb 14"		RXKG-BAD14	
Roofcurb 24"		RXKG-BAD24	
Economizer with Single Enthalpy ②		RXRD-KECM3	
Dual Enthalpy Kit		RXRX-AV02	
CO ₂ Sensor Only		RXRX-AR02	
Power Exhaust		RXRX-BFF04C	
Fresh Air Damper Manual		RXRF-FBA1	
Fresh Air Damper Motorized		RXRF-FBB1	
Rectangular to Round 18" Duct Adapters for Concentric Diffuser		RXMC-CB03	
Rectangular to Round 20" Duct Adapters for Concentric Diffuser		RXMC-CB04	
Concentric Diffuser 18" Step		RXRN-FA60	
Concentric Diffuser 18" Flush		RXRN-FA70	
Rectangular to Round 16" Side		RXMC-BB01	
Louver Kit (3 Sides)		RXRX-AAD01B	
Time Delay		RXMD-B01	
High Pressure		RXAB-A02	
Low Pressure		RXAC-A02	
Low Ambient Control to 0°F [-18°C]		RXRZ-A18	
LP Conversion Kits for use with White Rodgers Gas Valve ①		RXGJ-EP84W	
LP Conversion Kits for use with Honeywell Gas Valve ①		RXGJ-EP85H	
Canadian High Altitude Kit (for Natural Gas Only) ①		RXRX-AH01	

*Voltage 1 = 208/230 VAC-1PH-60HZ 4 = 460 VAC-3PH-60HZ
3 = 208/230 VAC-3PH-60HZ

NOTES: ① If a particular unit is to be converted to operate on **LP (propane)** for elevations above 2000 ft. in Canada, the existing Natural Gas to LP Conversion Kits for the subject models already contain the necessary orifices and instructions to de-rate the input for 2000-4500 ft. Canadian applications.

② Economizer is designed for downflow or horizontal applications.

ACCESSORIES

ROOFCURBS (Full Perimeter)

- This roofcurb design can be utilized on 3 through 5 ton models.
- Two available heights (14" and 24" for ALL models).
- Quick assembly corners for simple and fast assembly.
- Opening provided in bottom pan to match the "Thru the Curb" electrical connection opening provided on the unit base pan.
- 2" x 4" Nailers provided.
- Insulating panels provided.
- Sealing gasket 28" provided with Roofcurb.
- Packaged for easy field assembly.

Roofcurb Model	Height of Curb
RXKG-BAD14	14" [356 mm]
RXKG-BAD24	24" [610 mm]

TYPICAL INSTALLATION

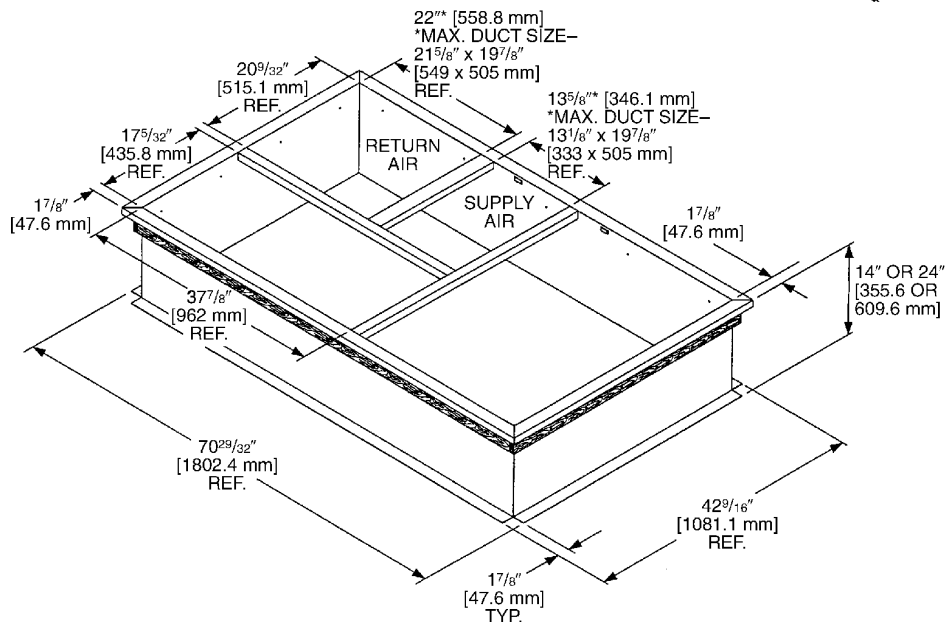
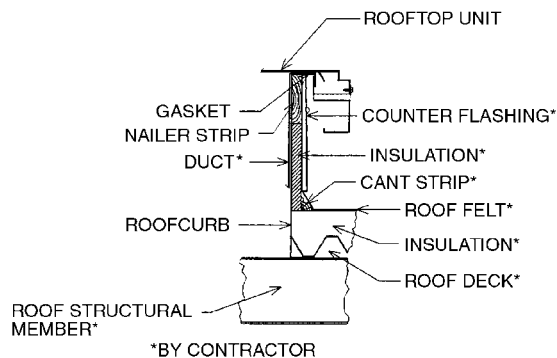
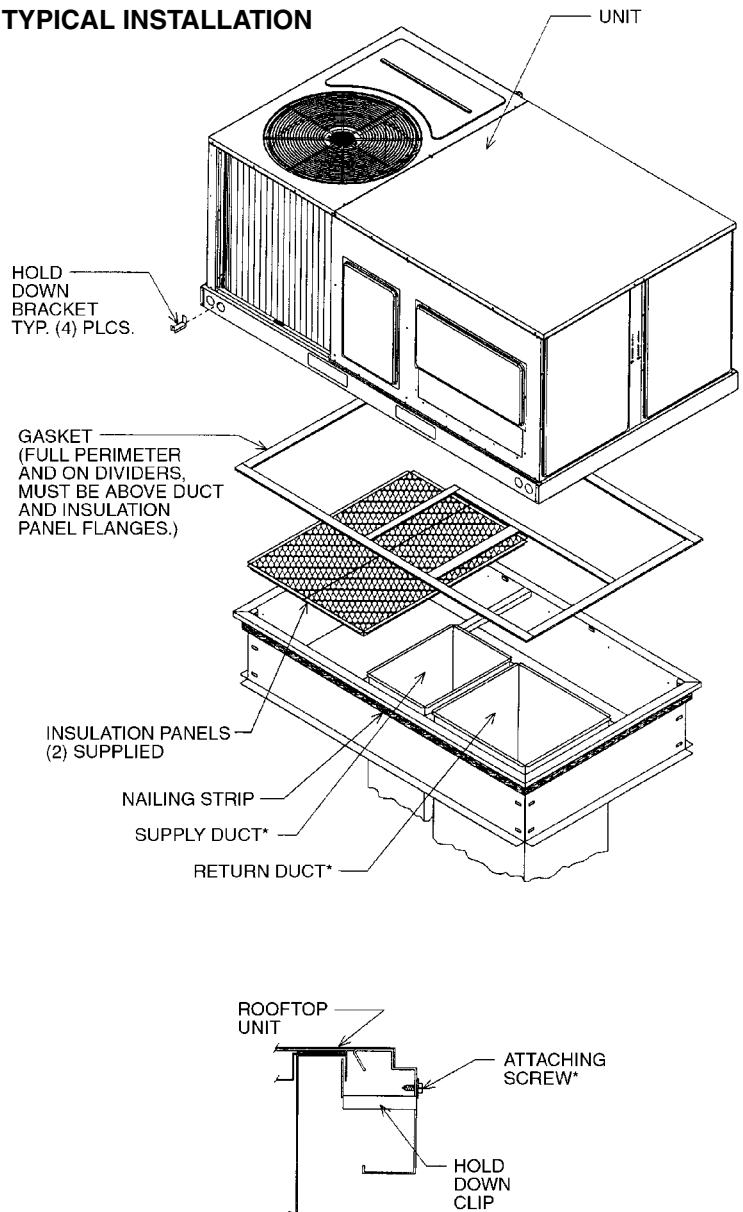

**ROOFCURB FOR
TGC036C-TGC060C MODELS**

ECONOMIZERS

RXRD-KECM3—Single Enthalpy with Barometric Relief

RXRX-AV02—Dual Enthalpy Kit

RXRX-AR02—CO₂ Sensor

- Features **Honeywell** Analog Controls
- Field installed accessory
- Gear Driven Direct Drive Actuator
- Fully Modulating (0-100%)
- Low Leakage Dampers
- **Horizontal or Downflow Applications**
- Slip-In Design for Easy Installations
- Plug-In Polarized 9-pin Electrical Connections
- Pre-configuring—No Field Adjustments Necessary
- Standard Barometric Relief Damper Provided
- Single Enthalpy with Dual Enthalpy upgrade kit
- CO₂ Input Sensor Available
- Economizer slips in complete for downflow or horizontal duct applications
- Field assembled hood ships with Economizer
- Optional Remote minimum position
- Field installed power exhaust available.

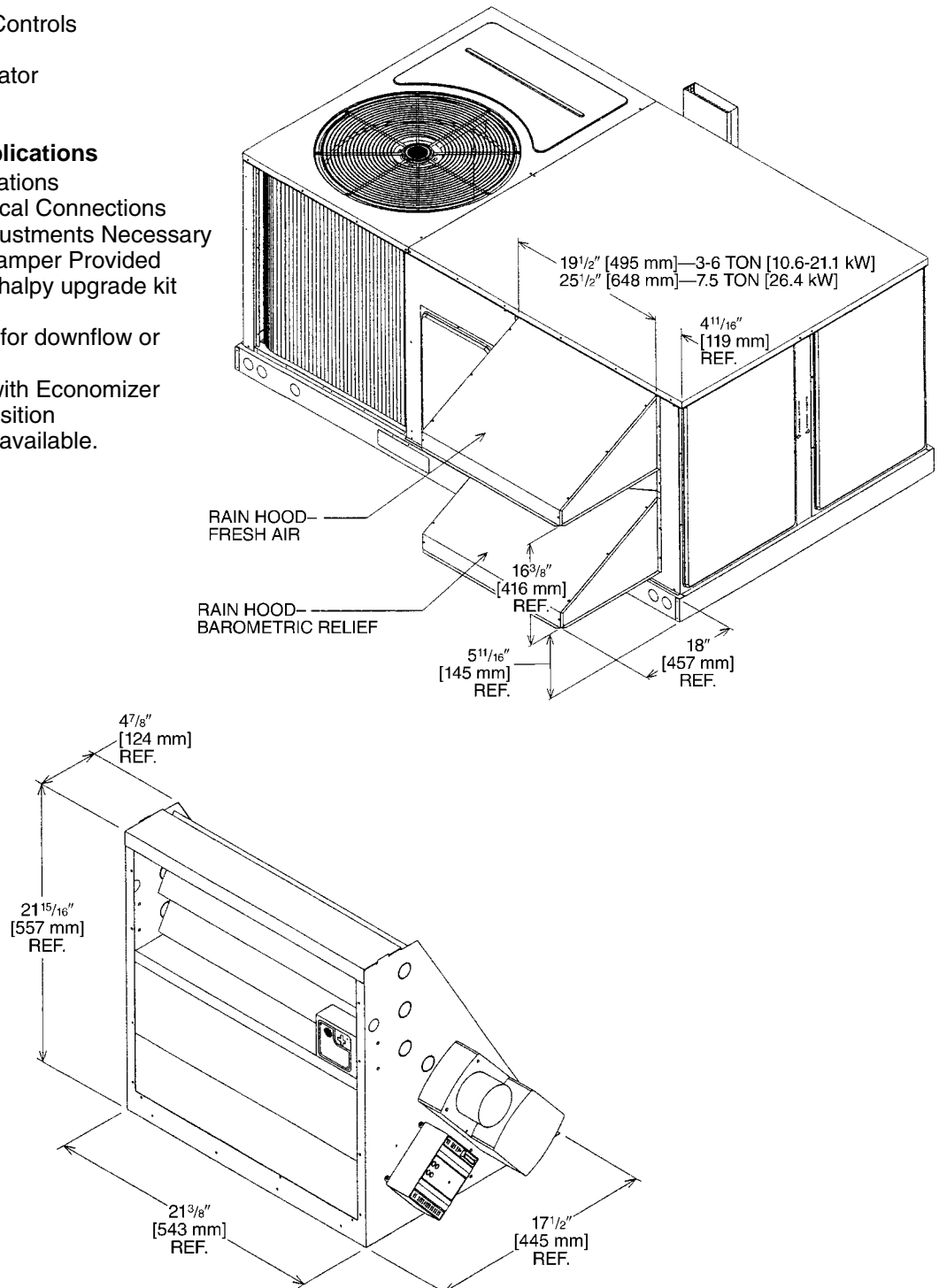

ACCESSORIES

INTEGRAL POWER EXHAUST FOR ECONOMIZER

RXRX-BFF04C—208/230V-1phase

- For **Honeywell** economizer.
- Downflow or horizontal applications.
- Requires separate 208-230 volt – 1 PH power supply with disconnect.
- Adjustable switch on economizer, factory preset to energize power exhaust at 95% outside air position.
- Polarized plug connects power exhaust relay to economizer.

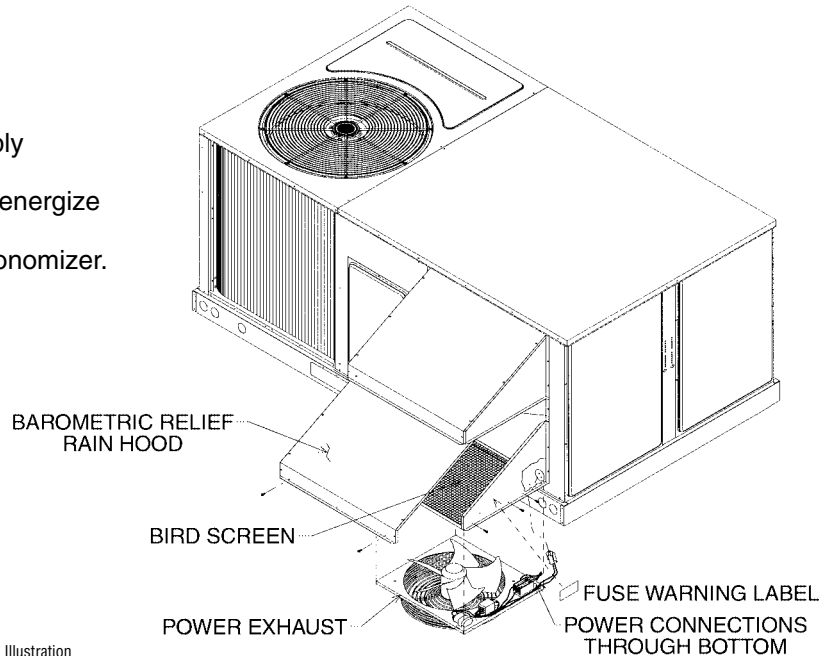

Illustration
ST-A0903-01

POWER EXHAUST KIT SPECIFICATIONS

Model No.	No. of Fans	Volts	Phase	Watts (ea.)	High Speed		FLA (ea.)	LRA (ea.)
					CFM ①	RPM		
RXRX-BFF04C	1	208-230	1	240	2600	1700	1.06	1.9

① CFM is at 0" W.C. external static pressure.

FRESH AIR DAMPER

RKNA 3-5 Ton [10.6-17.6 kW] Models

RXRF-FBA1 (Manual)

RXRF-FBB1 (Motorized)

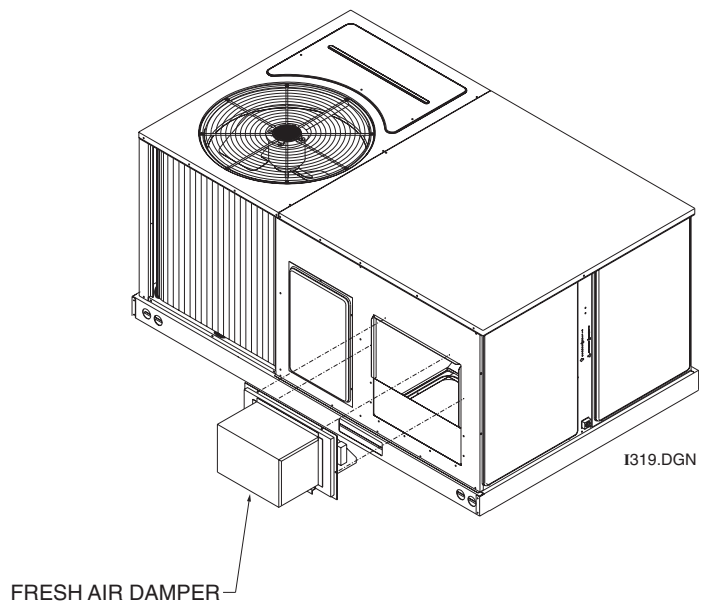

DUCT ADAPTERS

Rectangular to Round Transitions (Downflow)

RXMC-CB03 sizes available

18" fit all units.

Drops into and secures to
RXKG- Series Roofcurbs.

**For use with
Concentric Diffusers.**

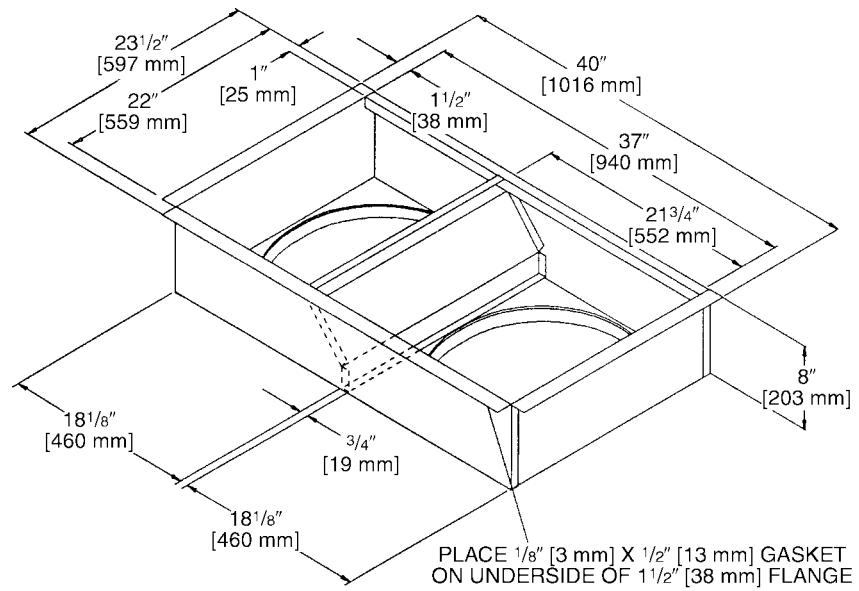

ACCESSORIES

SIDE DISCHARGE CONCENTRIC DIFFUSER

RXRN-FA60

For Use With Duct Adapter (RXMC)

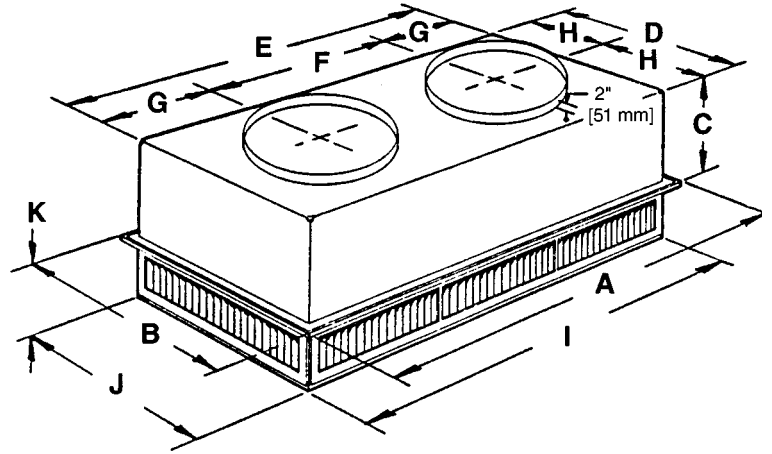

DIMENSIONAL DATA

Model No.	A	B	C	D	E	F	G	H	I	J	K	Duct Size
RXRN-FA60	47 ⁵ / ₈ " [1210 mm]	23 ⁵ / ₈ " [600 mm]	11 ³ / ₈ " [289 mm]	21 ¹ / ₂ " [546 mm]	45 ¹ / ₂ " [1156 mm]	22 ¹ / ₂ " [572 mm]	11 ¹ / ₂ " [292 mm]	10 ³ / ₄ " [273 mm]	45 ¹ / ₂ " [1156 mm]	21 ¹ / ₂ " [546 mm]	7 ¹ / ₈ " [181 mm]	18RD

ENGINEERING DATA

Model No.	CFM [L/s]	Static Pressure	Throw Feet	Neck Vel.	Jet Vel.	Noise Level
RXRN-FA60	1000 [472]	.14	10-17	351	351	20
	1200 [566]	.17	11-18	421	421	20
	1400 [661]	.20	12-19	491	491	20
	1600 [755]	.24	12-20	561	561	20
	1800 [850]	.30	13-21	632	632	20
	2000 [944]	.36	14-23	702	702	20
	2200 [1038]	.40	16-25	772	772	20

FLUSH MOUNT CONCENTRIC DIFFUSER

RXRN-FA70

For Use With Duct Adapter (RXMC)

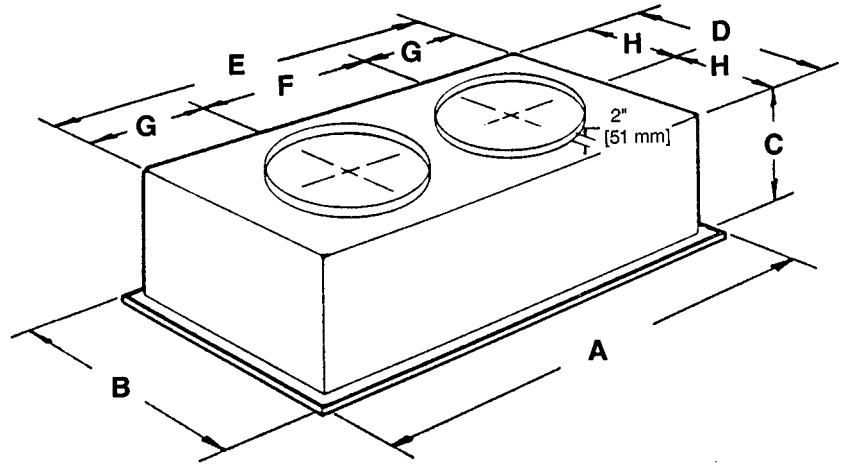

DIMENSIONAL DATA

Model No.	A	B	C	D	E	F	G	H	Duct Size
RXRN-FA70	47 ⁵ / ₈ " [1210 mm]	23 ⁵ / ₈ " [600 mm]	13 ¹ / ₂ " [343 mm]	21" [533 mm]	45" [1143 mm]	22 ¹ / ₂ " [572 mm]	11 ¹ / ₄ " [286 mm]	10 ¹ / ₂ " [267 mm]	18RD

ENGINEERING DATA

Model No.	CFM [L/s]	Static Pressure	Throw Feet	Neck Vel.	Jet Vel.	Noise Level
RXRN-FA70	1000 [472]	.14	15-20	391	694	20
	1200 [566]	.17	16-22	469	833	25
	1400 [661]	.20	17-24	547	972	30
	1600 [755]	.24	18-25	625	1111	30
	1800 [850]	.30	20-28	703	1250	35
	2000 [944]	.36	21-29	781	1389	40
	2200 [1038]	.40	22-30	859	1528	40

ACCESSORIES

THERMOSTATS GAS/ELECTRIC

RECOMMENDED THERMOSTATS WITH AND W/O ECONOMIZER

Single Stage Cool w/o Economizer	Two Stage Cool w/Economizer
Maple Chase—Model #0970	Honeywell—Model #T7300-A1005
Honeywell—Model #T8602C	Honeywell—Model #T874D-1959
Maple Chase—Model #0960	
White Rodgers—Model #1F91-59	
Robertshaw—Model #CM64A-USAJ	

WIRING SCHEMATIC—TGC036/060C-3K w/PSC

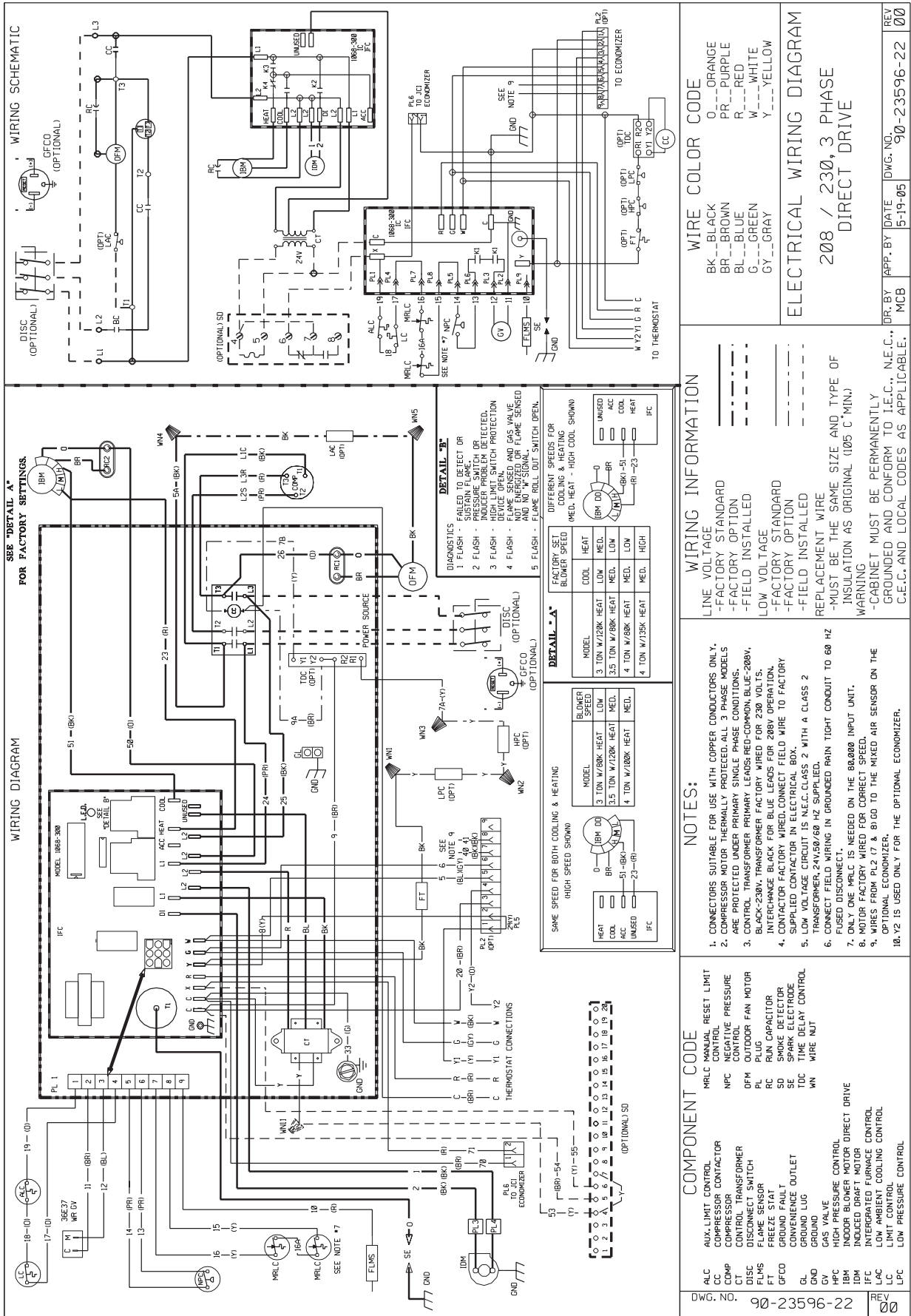

WIRING SCHEMATIC—TGC060C-4K w/BELT DRIVE

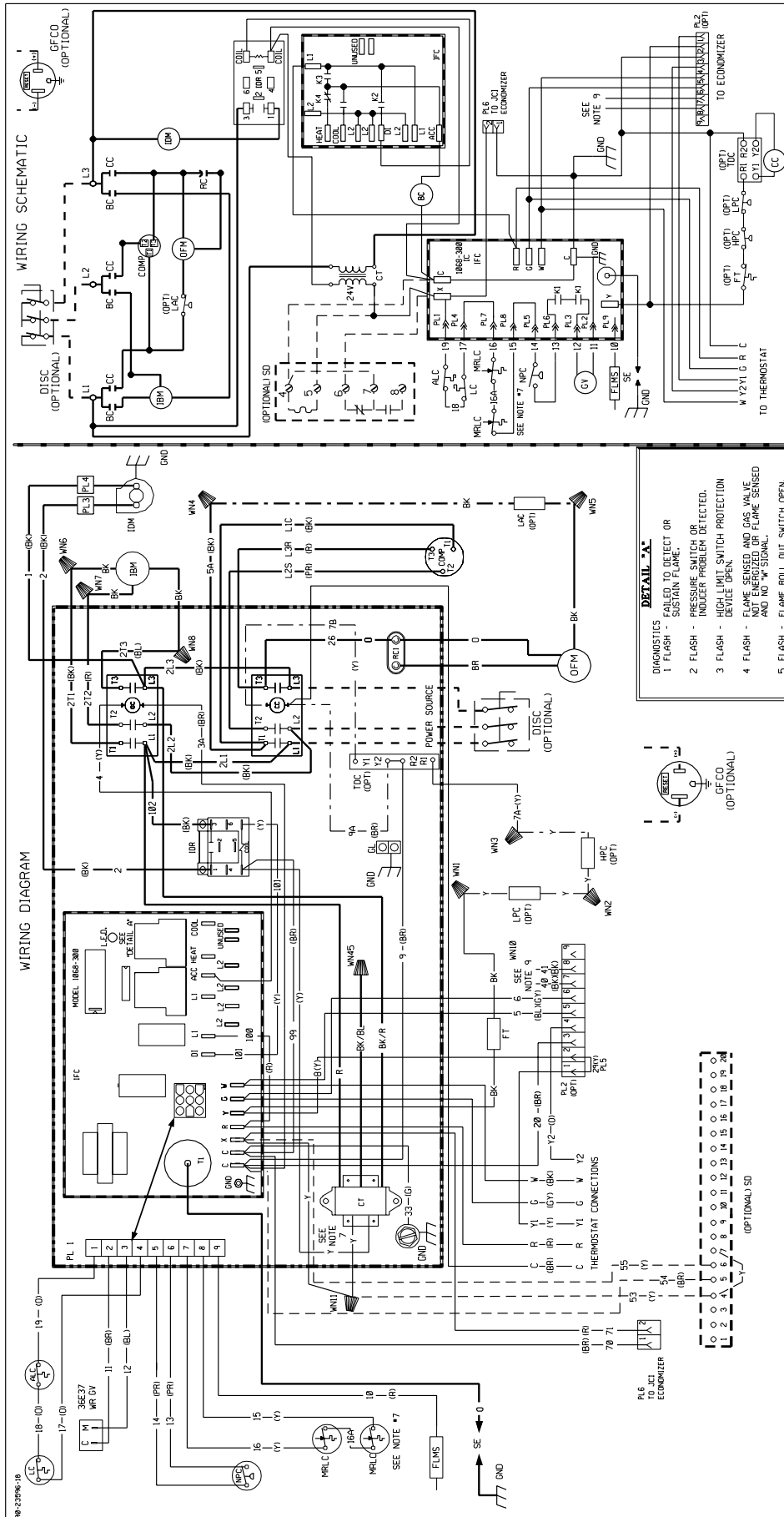

COMPONENT CODE	
AUX LIMIT CONTROL	ALC
BLOWER CONTACTOR	BC
COMPRESSOR CONTACTOR	CC
COMPRESSOR	COMP
CONTROL TRANSFORMER	CT
DISCONNECT SWITCH	DISC
FLAME SENSOR	FS
FREESTART	FT
GROUND FAULT CONVENIENCE OUTLET	GFCO
GROUND LUG	GL
GAS VALVE	GV
HIGH PRESSURE CONTROL	HPC
INDOOR BLOWER MOTOR	IDM
INDUCED DRAFT MOTOR	IDR
INDUCED DRAFT RELAY	IDR
INTEGRATED FURNACE CONTROL	IFC
LOW AMBIENT COOLING CONTROL	LAC

WIRE COLOR CODE	
BK	BLACK
BR	BROWN
BL	BLUE
BG	GREEN
CY	GRAY
W	WHITE
R	RED
O	ORANGE
PR	PURPLE
Y	YELLOW

ELECTRICAL WIRING DIAGRAM	
460 3 PHASE, 60 HZ BELT DRIVE	

WIRING INFORMATION	
LINE VOLTAGE	
-FACTORY STANDARD	
-FACTORY OPTION	
-FIELD INSTALLED	
LOW VOLTAGE	
-FACTORY STANDARD	
-FACTORY OPTION	
-FIELD INSTALLED	
REPLACEMENT WIRE	
-MUST BE THE SAME SIZE AND TYPE OF INSULATION AS ORIGINAL (105 C MIN.)	
WARNING	
-CABINET MUST BE PERMANENTLY GROUNDED AND CONFORM TO I.E.C., N.E.C., C.E.C. AND LOCAL CODES AS APPLICABLE.	

NOTES:	
1. CONNECTORS SUITABLE FOR USE WITH COPPER CONDUCTORS ONLY.	
2. COMPRESSOR MOTOR THERMALLY PROTECTED, ALL 3 PHASE MODELS ARE PROTECTED UNDER PRIMARY SINGLE PHASE CONDITIONS.	
3. CONTACTOR FACTORY WIRED, CONNECT FIELD WIRE TO FACTORY SUPPLIED CONTACTOR IN ELECTRICAL BOX.	
4. LOW VOLTAGE CIRCUIT IS N.E.C. CLASS 2 WITH A CLASS 2 TRANSFORMER, 24V/50/60 HZ SUPPLIED.	
5. CONNECT FIELD WIRING IN GROUNDED RAIN TIGHT CONDUIT TO 60 HZ FUSED DISCONNECT.	
6. ONLY ONE MRLC IS NEEDED ON THE 80,000 INPUT UNIT.	
7. POWER TRANSFORMER PRIMARY LEADS, BLUE-COMMON; BK/RED-480V, 60 HZ, 380V, 50 HZ; RED-575V, 60 HZ / 415V, 50 HZ.	
8. WIRES FROM PL 2 (7 & 8) GO TO THE MIXED AIR SENSOR ON THE OPTIONAL ECONOMIZER.	
9. Y2 IS USED ONLY FOR THE OPTIONAL ECONOMIZER.	

DIAGNOSTICS	
1 FLASH - FAN LED TO DETECT OR SUSTAIN FLAME.	
2 FLASH - PRESSURE SWITCH OR INDUCER PROBLEM DETECTED.	
3 FLASH - HIGH LIMIT SWITCH PROTECTION DEVICE OPEN.	
4 FLASH - FLAME SENSED AND GAS VALVE NOT ENERGIZED OR FLAME SENSED AND NO "W" SIGNAL.	
5 FLASH - FLAME ROLL OUT SWITCH OPEN.	

THERMOSTAT CONNECTIONS	
1	55
2	53
3	54
4	51
5	52
6	50
7	49
8	48
9	47
10	46
11	45
12	44
13	43
14	42
15	41
16	40
17	39
18	38
19	37
20	36
21	35
22	34
23	33
24	32
25	31
26	30
27	29
28	28
29	27
30	26
31	25
32	24
33	23
34	22
35	21
36	20
37	19
38	18
39	17
40	16
41	15
42	14
43	13
44	12
45	11
46	10
47	9
48	8
49	7
50	6
51	5
52	4
53	3
54	2
55	1

DETAIL - A	
FAN LED TO DETECT OR SUSTAIN FLAME.	
PRESSURE SWITCH OR INDUCER PROBLEM DETECTED.	
HIGH LIMIT SWITCH PROTECTION DEVICE OPEN.	
FLAME SENSED AND GAS VALVE NOT ENERGIZED OR FLAME SENSED AND NO "W" SIGNAL.	
FLAME ROLL OUT SWITCH OPEN.	

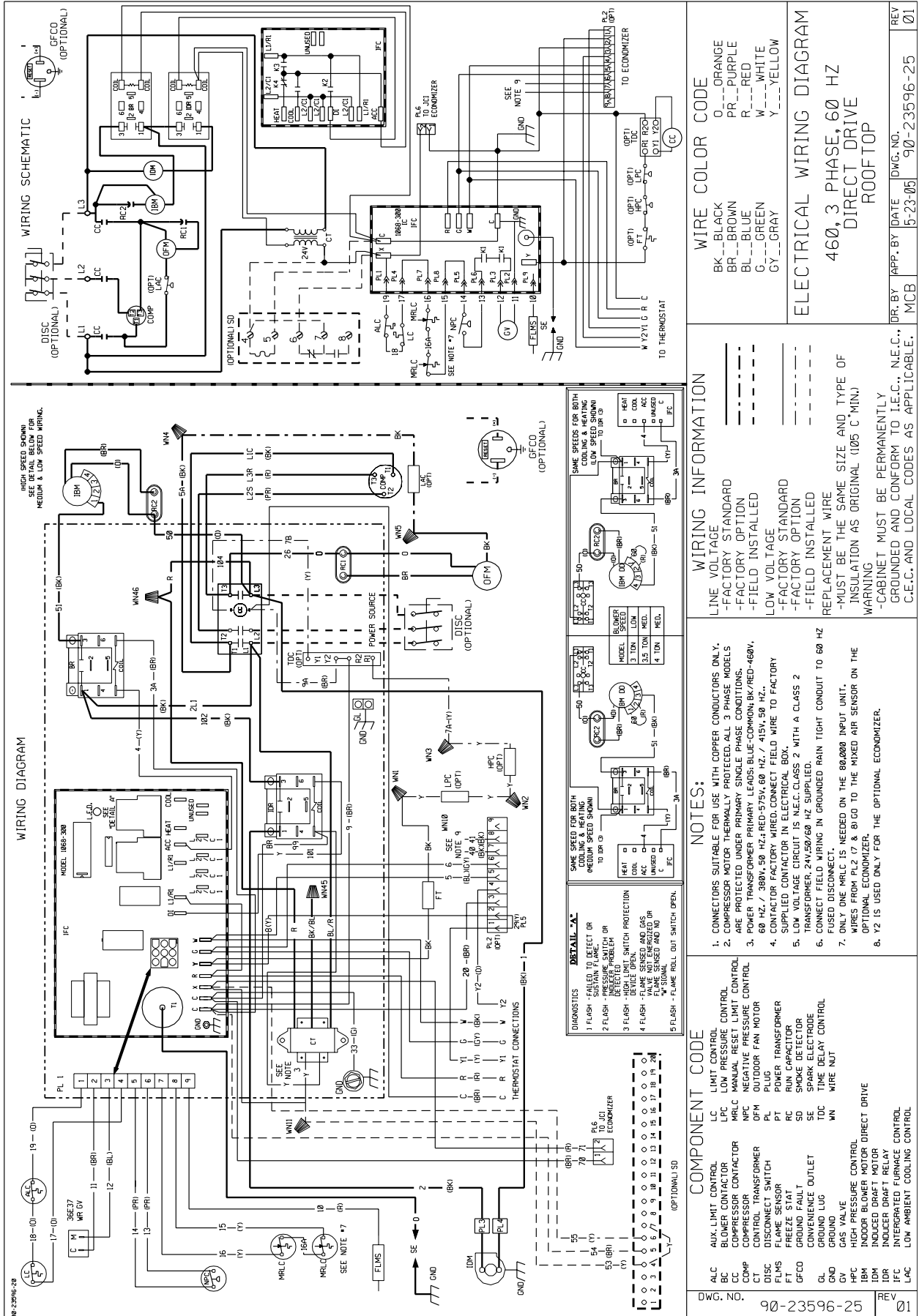

**Design, material, performance data and components
subject to change without notice.**

HEAT CONTROLLER, INC.

1900 Wellworth Ave Jackson, Michigan 49203 • Ph. 517-787-2100 • Fax 517-787-9341

THE QUALITY LEADER IN CONDITIONING AIR

www.heatcontroller.com